

DAQ6510 Data Acquisition and Logging, Multimeter System

DATASHEET



The DAQ6510 is a precision data acquisition and logging system that creates a new level of simplicity compared with the often complicated configuration and control found in many stand-alone solutions. A large 5-inch (12.7 cm) multi-touch display will guide users through set-up, data visualization, and analysis, removing the necessity of a PC and custom software for many applications. If you prefer or require a PC, a complement of IVI and Labview drivers and the Keithley KickStart Instrument Control Software are available to help with any application.

Using Keithley's newest 6½-digit multimeter technology, you will find even greater accuracy, functionality, and speed. Two-year accuracy specifications are included, so you can be assured your critical measurements remain accurate and fully traceable.

With 12 plug-in switching and control modules available and two module slots, you can build a test system that can measure or control up to 80 devices-under-test (DUTs) in a multiplexing configuration. With two 6x8 matrix modules, a total of 96 crosspoints, the DAQ6510 can test one or multiple ICs. For high volume production testing, select a solid state multiplexer module to maximize throughput with 800 channels/s scanning speed and minimize downtime compared with fixed life, electro-mechanical relays. A number of modules have cold junction compensation, temperature references for thermocouple temperature monitoring of devices during environmental testing, and HALT and HASS accelerated life testing. Even switch signals from wireless devices with RF modules having a maximum switching frequency of 3.5 GHz.

Key Features

- Large, 5-inch (12.7 cm) multi-touch capacitive touchscreen with graphical display
- 2-year specified, full featured, traceable 6½-digit multimeter with 0.0025% DCV (1 V, 10 V ranges) basic accuracy
- Standard LAN/LXI and USB-TMC communication interfaces
- Optional interfaces include GPIB, RS-232, and TSP-Link® Technology
- 10 different switch and control modules to connect to as many as 80 DUTs in one test set-up
- Up to 80 2-pole channels of thermocouple, RTD, or thermistor temperature measurements
- Scanning speeds as high as 800 channels/second with the solid state relay module
- Front panel jacks for stand-alone DMM operation
- KickStart easy-to-use control software with a data acquisition and logging application
- Three-year warranty

Visualize, Execute, and Debug Your Test Setup in Minutes

Build a test sequence and define the required measurements from one setup screen. First, select the channels that will be used. Next, assign a measurement function to a channel or a group of channels. Then define



both the time interval between measurements and scans if multiple scans are required. That is the minimum set of parameters needed to run a test. There are additional optional parameters to adjust the measurements and the switching to meet a specific application. One option eases the identification of channels by allowing the creation of a name for each channel. Do all this from two menus and see – on one screen – how each channel is configured. The touchscreen, graphic display shows the channel setup and the measurement programmed for each channel.

To test channels during setup, manually close channels on the setup screen. The measurement on that channel is displayed next to the closed channel. Thus, channel performance can be verified during set up or debugged if the measurement is out of the expected range before the test is executed.

Maximize the Range of Tests with an Extensive Array of Plug-In Switch Modules

Build a DAQ6510 test system with a selection of 12 plug-in switch modules with a wide range of functionality. Select from high-density, 40-channel multiplexer modules, a 6×8 matrix module, and multiplexer modules with digital I/O and analog output. Also select a control module and two RF modules with 2 GHz and 3.5 GHz bandwidths. Thus, the DAQ6510 with its 12 switch modules provides an extensive range of flexibility to build a wide range of data acquisition or test systems.

Channels can be configured for any DMM measurement. For example, measure the temperature of devices in an environmental chamber with thermocouples using the plug-in switch modules that have automatic cold reference junction compensation for thermocouple measurements. Measure up to 80 devices with two switch modules. Also measure other parameters in addition to temperature. The low frequency, multiple pole switch modules can allow measurement of voltage, 2-wire- and 4-wire resistance, and frequency. In addition, two modules have current measurement channels.



Series 7700 Plug-in Switch Modules.

DAQ6510 Touchscreen Display Front Panel

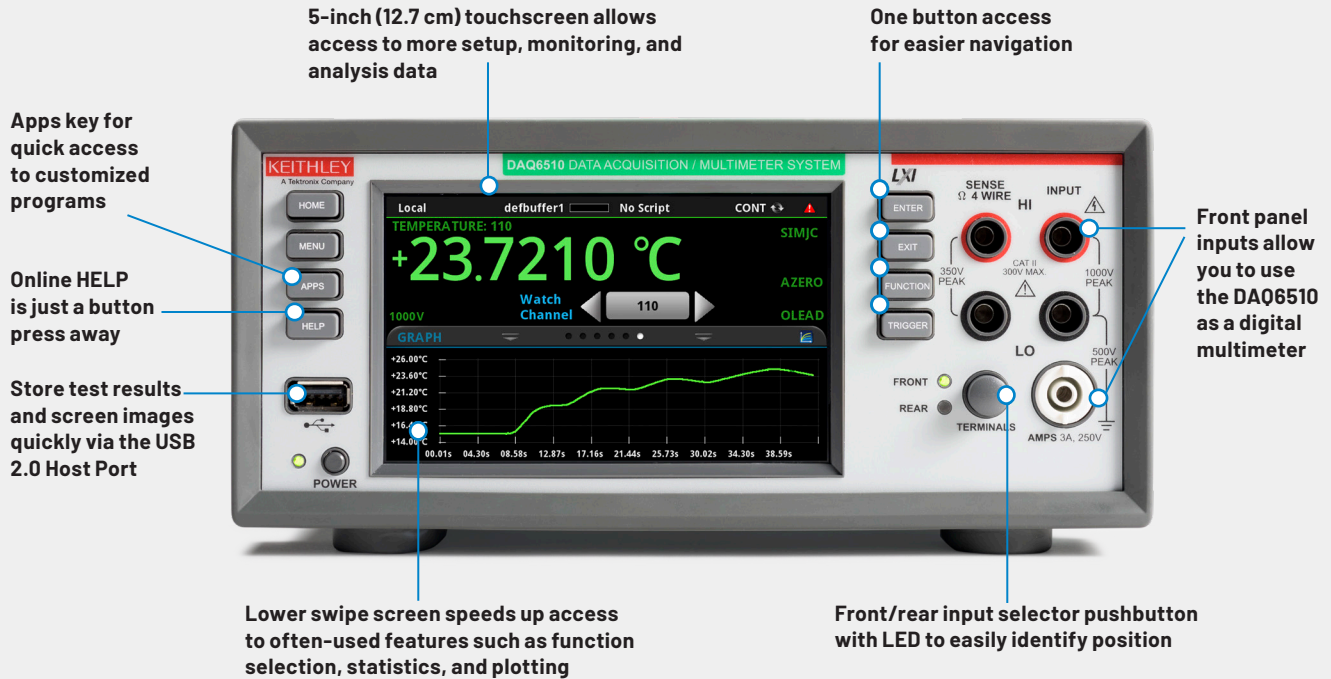

DAQ6510 Rear Panel

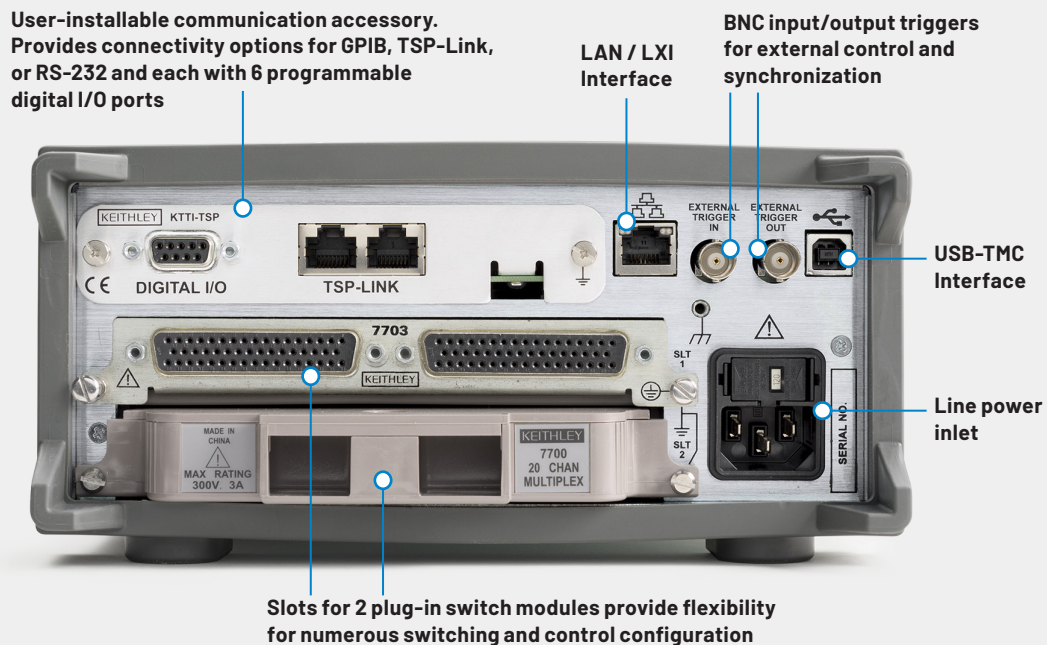

Test a Wide Range of Devices and Components with 6½-digit DMM High Performance Measurements

Make your measurements with instrument-grade quality. The DAQ6510 is a fully-featured 6½-digit DMM. The chart below shows all of the DAQ6510's 15 measurement functions and ranges. All these measurement functions can be used with the various plug-in switch modules. Furthermore, a channel can be programmed for enhanced measurement features to address requirements for tighter tolerance or higher speed.

For maximum accuracy, measurements can be filtered and integrated over a range of time intervals. Low resistance readings can be improved with a thermal offset compensation measurement technique. The DAQ6510 excels in low resistance measurement with 1 μΩ sensitivity.

For maximizing measurement speed, make measurements as short as 0.0005 power line cycles (PLCs) or 8.3 μs for 60 Hz power lines (10 μs for 50 Hz power lines). To analyze transient signals, use the DAQ6510's digitizing function to sample a voltage or current waveform at up to 1M sample/s.

DAQ6510 Measurement Capabilities

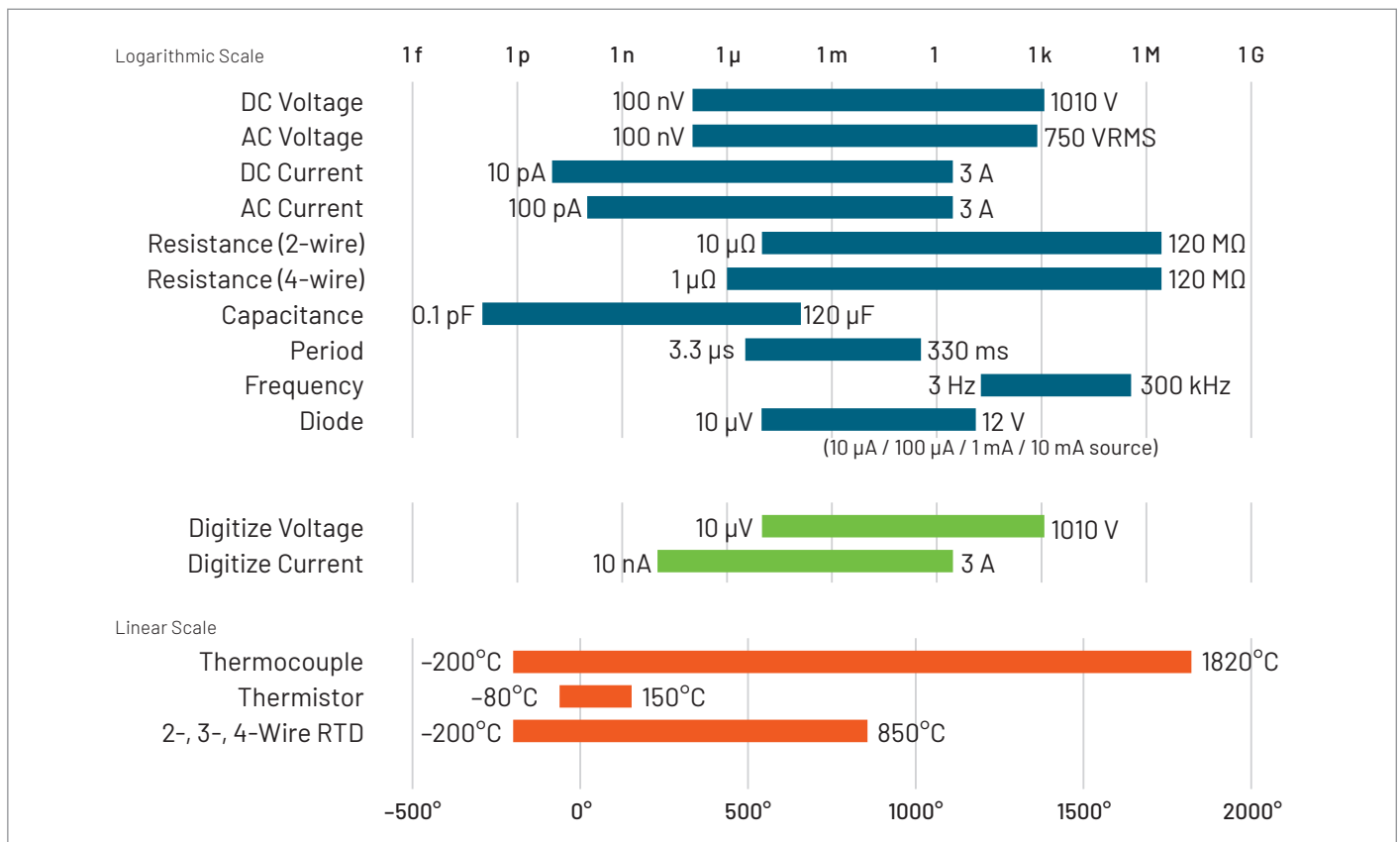

DAQ6510's 15 measurement functions and ranges.

Monitor Any Temperature Range and Select Optimal Accuracy Using a Wide Range of Temperature Sensors

The DAQ6510 can process signals from any of eight thermocouple types to test over an extreme range of temperatures, -200°C to 1820°C. For more accurate temperature readings over a more narrow temperature range, the DAQ6510 can measure temperature from -80°C to 150°C with a 2-year accuracy of 0.08°C using 2.5 kΩ, 5 kΩ, and 10 kΩ thermistors. Alternatively, the DAQ6510 can measure temperature between -200°C and 850°C using resistance temperature detectors (RTDs) with 2-wire, 3-wire, and 4-wire configurations. Using a 4-wire RTD, temperature can be measured with with an excellent 2-year accuracy of 0.06°C.

The Series 7700 plug-in switch modules have multiple cold junction compensation (CJC) circuits. The CJC circuits are spaced around the module to ensure maximum accuracy for all channels measuring thermocouples.



Use a pinch and zoom display feature for detailed study of test data.

Save Valuable Time with Continuous Monitoring of Scan Test Status

Never lose time with a test in which a problem such as a broken wire, a mis-wired connection, or a defective DUT can invalidate days of data. Use the scan status, swipe screen to continuously monitor channels. The status screen shows

the percentage of the test that has been completed, the number of scans that have been completed, measurements on channels selected for monitoring, and whether any measurements are out of range. A quick view of the display can give an indication of the status of the test at any time during the test. In addition to an indication of measurements in an overflow condition, limit settings can be programmed for any channel. The Status screen will display an out-of-limit indication when any channel's measurement is outside the channel's limit settings.

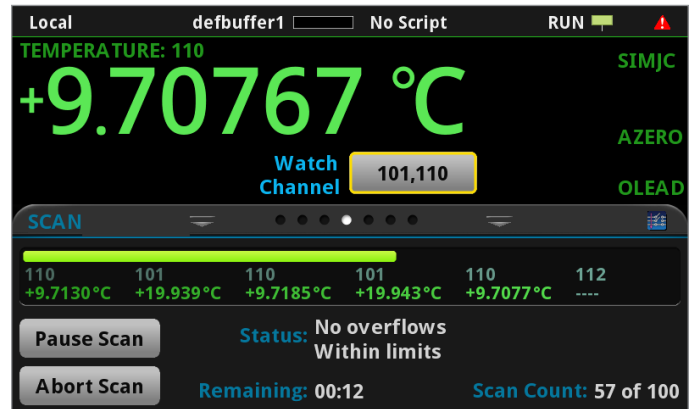

Quickly and easily monitor the status of a test using the DAQ6510 scan status screen.

Maintain an Automated Test while Interacting with the Instrument

Need to perform a quick check to ensure there are no problems with the measurements that the DAQ6510 is taking? Want to review the trend of the data? The DAQ6510 can be operated from the front panel while a test is in progress. Data can be viewed in a table or displayed on a plot without interrupting an automated scan sequence.

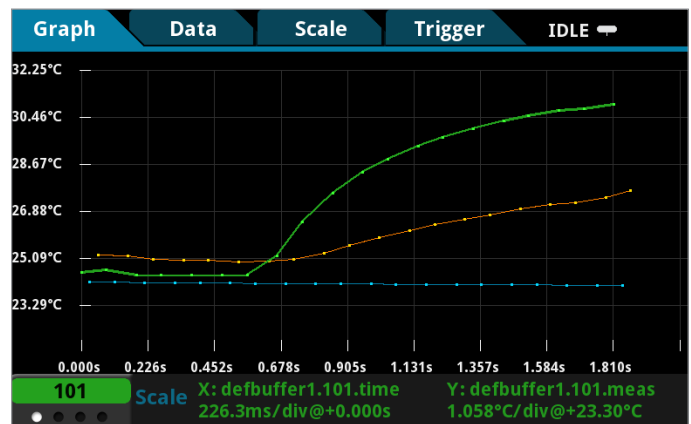

Graphically view data during or at the end of a test. Display up to 20 channels on one plot.

Never Lose Data and Test Time

Data can be stored to an external USB memory stick to prevent data loss in the event of interruption of line power. The DAQ6510 also has an option to automatically restart scanning after a power interruption. If main power is lost, the DAQ6510 will re-start the scan when the power is restored. The new data will be stored in a separate data buffer with time-stamped measured data so that the lost time due to the power failure can be noted. Of most importance, there is no lost test time due to the instrument sitting idle following a power outage.

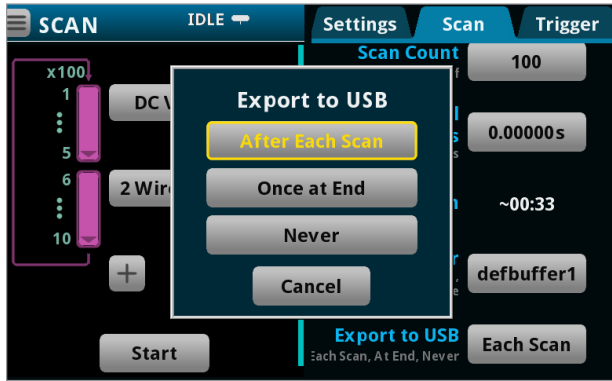

Select how you want to store data in the Scan menu.

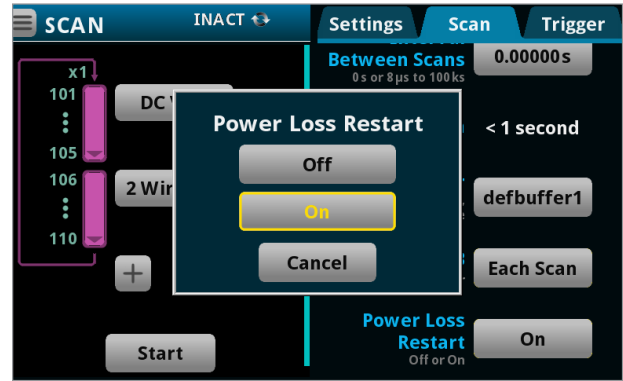

Choose to automatically restart a test after a power loss.

Save Test Time in Automated Test Systems

To maximize throughput and minimize total test time, use the reed relay or the solid state relay multiplexer module to achieve scanning speeds up to 800 channels/s. Also save test time by reducing communication with the test controller. The DAQ6510 has the built-in intelligence to execute a test script, make decisions, and control other instruments. The DAQ6510 has Keithley's Test Script Processor (TSP®) measurement and control language that the user can use to either execute existing scripts or write custom scripts to run tests. TSP® scripting allows running powerful test scripts directly on the instrument, without the need for an external PC controller. These test scripts are complete test programs based on an easy-to-use yet highly efficient and compact scripting language, LUA (www.lua.org). Scripts are a collection of instrument control commands and/or program statements. Program statements control script execution and provide facilities such as variables, functions, branching, and loop control. This allows you to create powerful measurement applications without an integrated development environment (IDE). Test scripts can contain any sequence of routines that are executable by conventional programming languages (including decision-making algorithms), so the instrument can manage every facet of the test without the need to communicate with a PC for decision making. This eliminates delays due to GPIB, Ethernet, or USB traffic congestion and greatly improves test times.

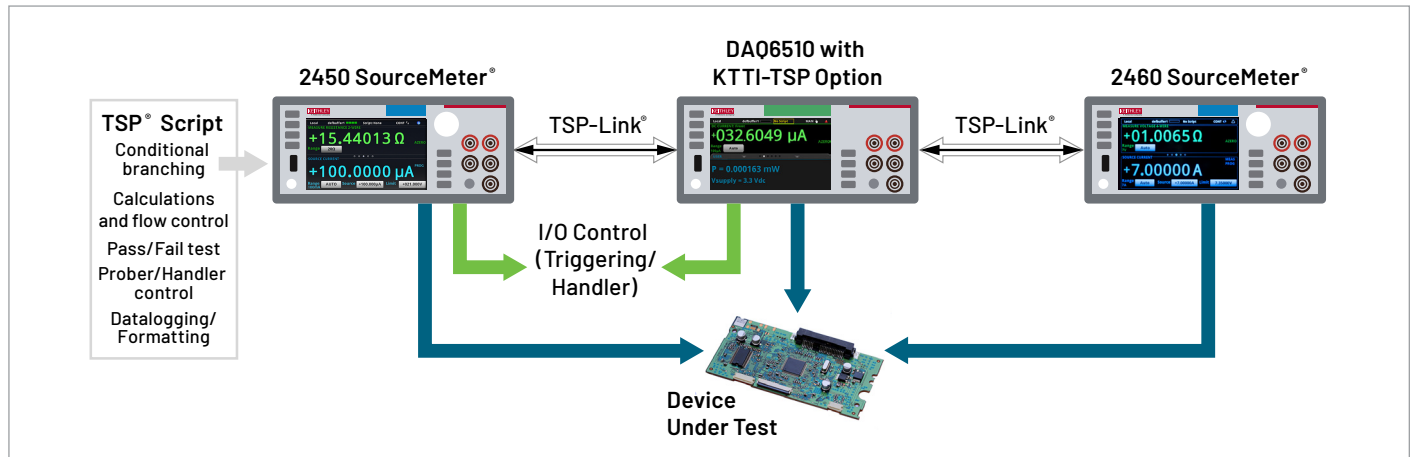

Use a TSP script and the TSP-Link interface to execute a test for instrument-to-instrument communication without interaction with a computer.

TSP® technology also offers mainframe-less channel expansion. The KTTI-TSP is a user installable accessory card offering connectivity to TSP-Link technology. This channel expansion bus allows connecting multiple DMM6510's, other TSP-enabled instruments, and any LAN-based instruments together to form a tightly-synchronized instrument system. Connection is provided with simple low cost Category 5 Ethernet crossover cabling. The system is organized in a master-subordinate configuration, essentially allowing the connected instruments to act as one. Other Keithley TSP-enabled instruments include the 2450, 2460, and 2461 Graphical SourceMeter® Source Measure Unit (SMU) Instruments, Series 2600B SourceMeter® (SMU) Instruments, DMM7510, DMM6500, and Series 3700A Switch/ Multimeter systems. TSP-Link technology supports up to 32 instruments, so it's easy to scale a system to fit the requirements of an application.

With the TSP-Link interface option, the KTTI-TSP, the DAQ6510 can control other Keithley TSP instruments or control any instrument with a LAN interface. For example, the DAQ6510 can send commands to a temperature chamber to operate at specific temperatures and execute a scan when the chamber has reached the programmed temperatures. In fact, the DAQ6510 can execute an automated sequence entirely without a PC thus saving test time and reducing the capital cost of the system. Using the TSP language to create a script, the user can display messages for an operator in an automated or a semi-automated test system.

```
function configDCVScan(chanList, range, nplc, scanCount)
-- Basic DCV scan setup with ranging option...
channel.setdmm(chanList, dmm.ATTR_MEAS_FUNCTION, dmm.FUNC_DC_VOLTAGE)
channel.setdmm(chanList, dmm.ATTR_MEAS_NPLC, nplc)
if range < 0.9 then
    channel.setdmm(chanList, dmm.ATTR_MEAS_RANGE_AUTO, dmm.ON)
else
    channel.setdmm(chanList, dmm.ATTR_MEAS_RANGE, range)
end

-- Build the scan list
scan.create(chanList)
-- Set the scan count
scan.scancount = scanCount
end

-- Apply system defaults
rst()

-- Loop to test DUTs with different scan setups...
for i = 0, 10 do
-- Measure shunt resistor
config4WScan("107", 100.0, 0.2, 1)
trigScan()
getScanReadings()
-- Measure level-setting resistor
config2WScan("102:106", 0, 0.02, 1)
trigScan()
getScanReadings()
-- Measure on-board regulators
configDCVScan("111:115", 10.0, 0.02, 1)
trigScan()
getScanReadings()
-- Check current draw of DUT
configDCIScan("121", 1.0, 0.02, 1)
trigScan()
getScanReadings()
end
```

TSP scripting example.

Data Logging Software Simplifies PC Control, Acquisition, and Analysis

KickStart allows you to configure, test, and collect data from multiple instruments, including DMMs, power supplies, SMU instruments, and dataloggers. You can control up to eight instruments at the same time and retrieve millions of readings from each instrument. This makes KickStart a great solution for your datalogging needs and for capturing lots of data from transient events with a digitizing DMM.

Getting insights quickly is important, so KickStart plots your data immediately and dedicates a large portion of the viewing area to the graph, while also allowing you to view and edit the most essential parameters of other instruments in your test setup. Kickstart also includes comparison tools to allow you to plot and overlay data from the run history of each test.

KICKSTART DATA LOGGING APPLICATION

Use the datalogger application to set up, program, and control the DAQ6510. Within minutes, configure channels, set measurement parameters such as limits and trigger sources, and view results in real time.

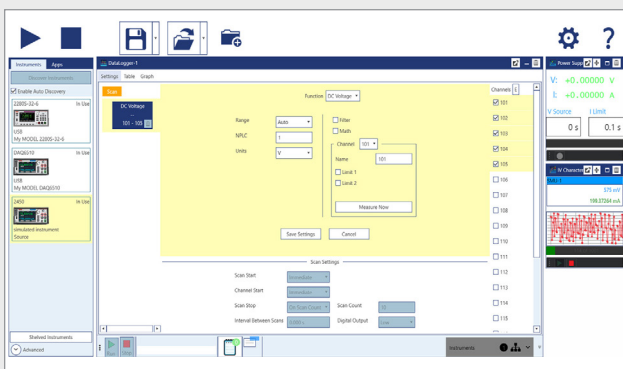

Datalogger setup screen.

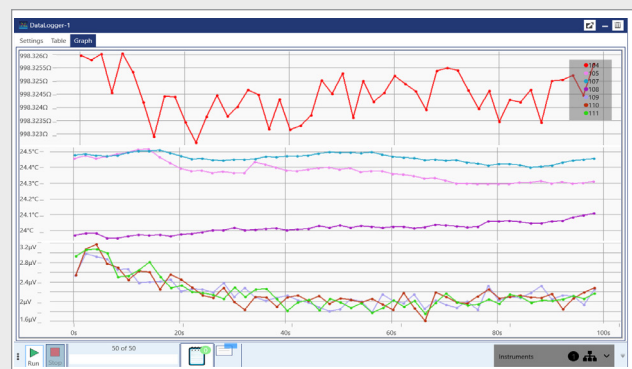

Datalogger multi-channel plot display screen.

Key KickStart features:

- Automate data collection from up to eight instruments
- Replicate tests quickly using saved test configurations
- Use statistical summaries and built-in plotting and comparison tools to quickly discover measurement anomalies and trends
- Export data in ready-to-use formats for additional analysis or to share test updates with your colleagues

Application Programs Expand DAQ6510 Utility

Add customized applications to the DAQ6510 to enhance the instrument’s capability.

The DAQ6510 includes factory-installed applications that:

- Allow creation of a modified display to show data from multiple channels.
- Report plug-in module relay closure counts that enable determination of when a plug-in module needs to be replaced.

These examples highlight the unique ability of the DAQ6510 to run specialized applications that customize the user interface. This can significantly change the way information is displayed or even automated while running a test.

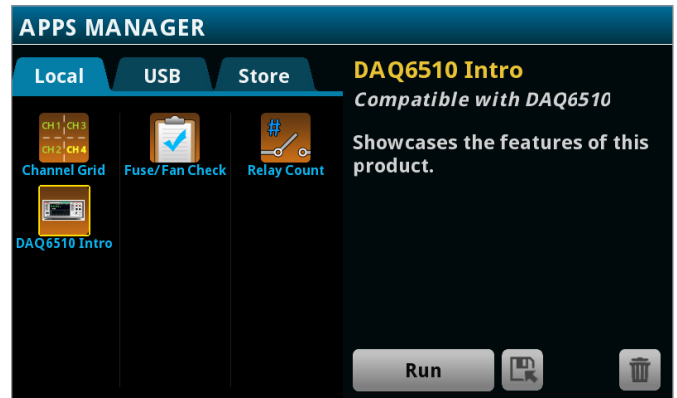

Ready to Use Instrument Drivers Simplify Programming

Prefer to create your own customized application software? Native National Instruments Labview®, IVI-C, and IVI-COM drivers are available for downloading to simplify the programming process. For the DAQ6510 Labview driver, please visit www.ni.com; for IVI drivers please visit www.tek.com.

Wide Range of PC Interfaces

You can choose the interface that is most suitable for your needs. Two PC interfaces, LAN LXI and USB, on the DAQ6510 are standard. In addition, field-installable interface options include a GPIB interface, an RS-232 interface, and the Keithley TSP-Link interface. All these options include six digital I/O ports for direct instrument-instrument synchronization and communication.

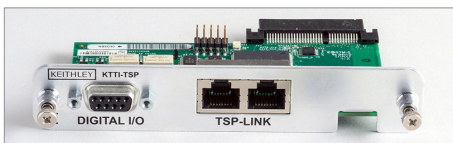

KTTI-TSP TSP-Link interface with 6 digital I/O ports.

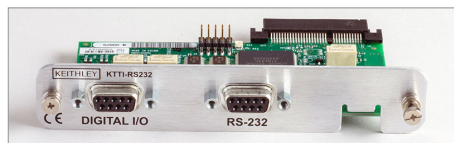

KTTI-RS232 RS-232 interface with 6 digital I/O ports.



KTTI-GPIB GPIB interface with 6 digital I/O ports.

Use as a DMM for Test and Troubleshooting

The DAQ6510 has front panel input terminals that enable use of the DAQ6510 as a 6½-digit DMM. When multiple channel measurements are not needed, the DAQ6510 functions as a DMM. Use the DAQ6510 with its front panel terminals to troubleshoot a test setup, a circuit, or to verify the value of a component. Save bench space and cost with an instrument that performs like a DMM and a data logger. The dual functionality enables maximized utilization of your instrument.



With its front panel connections, the DAQ6510 can be used as a 6½-digit DMM.

Reduce Test System Downtime and Save on Lifetime Costs

Unplanned system downtime results in loss of productivity and delayed product shipments or loss of valuable development time during product audit testing, accelerated life testing, and environmental testing. To avoid unplanned downtime, the DAQ6510's plug-in switch modules have counters for each relay that monitor the number of relay contact closures. Thus, when relay switch closures approach the manufacturers' relay life specification, the switch card module can be replaced during scheduled maintenance.



Many of the plug-in switch modules have multi-pin D-sub connectors to ensure secure, minimal maintenance connections in automated test environments. The D-sub connectors minimize downtime when changing plug-in switch modules during system maintenance or during the setup of a new test system.

The DAQ6510 is specified for both 1-year and 2-year accuracy specifications with little difference between the 1-year and 2-year specifications. Thus, for most applications, the calibration cycle for the DAQ6510 can be two years. This will reduce the life cycle costs on your DAQ6510 by half.

The DAQ6510 will save on unplanned system downtime, minimize planned downtime, and save on lifetime calibration costs making the DAQ6510 a highly economical asset in any test system.

Plug-In Module Selector Guide

Module Details

Model Number	7700	7701	7702	7703	7705	7706	7707	7708	7709	7710
Description	20 Channel, Differential Multiplexer Module	32 Ch. Differential Multiplexer Module	40 Ch. Differential Multiplexer Module	32 Ch. High Speed, Differential Multiplexer Module.	40 Ch. Single-pole Control Module	All-in-One I/O Module.	32 Ch. Digital I/O Module	40 Ch. Differential Multiplexer Module	6x8 Matrix Module.	20 Ch. Solid-state Differential Multiplexer Module
No. Analog Inputs	20	32	40	32	40	20	10	40	48	20
Configuration	Multiplexer w/ CJC 1x20 or two 1x10	Multiplexer 1x32 or two 1x16	Multiplexer 1x40 or two 1x20	Multiplexer 1x32 or two 1x16	Independent SPST	Multiplexer w/ CJC 1x20 or two 1x10	Digital I/O/ Multiplexer 1x10 or two 1x5	Multiplexer w/ CJC 1x40 or two 1x20	Matrix 6x8	Multiplexer w/ CJC 1x20 or two 1x10
Connector Type	Oversized screw terminal	50 pin female D-sub and 25 pin female D-sub	Oversized screw terminal	Two 50 pin female D-sub	Two 50 pin female D-sub	Screw terminal	50 pin male D-sub and 25 pin female D-sub	Oversized screw terminal	50 pin female D-sub and 25 pin female D-sub	Quick disconnect screw terminal
Max. Voltage	300 V	150 V	300 V	300 V	300 V	300 V	300 V	300 V	300 V	60 V
Max. Switched Current	1 A	1 A	1 A	500 mA	2 A	1 A	1 A	1 A	1 A	0.1 A
Bandwidth	50 MHz	2 MHz	2 MHz	2 MHz	10 MHz	2 MHz	2 MHz	2 MHz	2 MHz	2 MHz
Contact Life¹	10 ⁸	10 ⁸	10 ⁸	10 ⁸	10 ⁸	10 ⁸	10 ⁸	10 ⁸	10 ⁸	10 ¹⁰
Switch Speed	3 ms	3 ms	3 ms	1 ms	3 ms	3 ms	3 ms	3 ms	3 ms	0.5 ms
Other Details	Max. power = 125 VA. 2 current measure channels	Max. power = 125 VA.	Max. power = 125 VA. 2 current measure channels	Reed relays	Max. power = 125 VA	2 analog outputs. 16 digital outputs. Max. power = 125 VA	32 digital I/O. Max. power = 125 VA. Event Counter/ Totalizer	Max. power = 125 VA	Connects to internal DMM. Daisy chain mult. cards for up to 6x16 matrix (DAQ6510). Max. power = 125 VA.	Solid state relays, 800 ch./second scan rate

1. No load contact life. See switch module data sheet for additional specifications.

Module Function Capabilities

Model Number	7700	7701	7702	7703	7705	7706	7707	7708	7709	7710
DC Volts	✓	✓	✓	✓		✓	✓	✓	✓	✓
DC Current	✓		✓							
Temperature										
T/C w/ Automatic CJC	✓					✓		✓		✓
T/C w/ External CJC	✓	✓	✓	✓		✓	✓	✓	✓	✓
RTD	✓	✓	✓	✓		✓	✓	✓	✓	✓
Thermistor	✓	✓	✓	✓		✓	✓	✓	✓	✓
Resistance (2- or 4-wire)	✓	✓	✓	✓		✓	✓	✓	✓	✓
Continuity	✓	✓	✓	✓		✓	✓	✓	✓	✓
AC Volts	✓	✓	✓	✓		✓	✓	✓	✓	✓
AC Current	✓		✓							
Frequency	✓	✓	✓	✓		✓	✓	✓	✓	✓
Event Counter/ Totalizer						✓				
Digital Input							✓			
Digital Output						✓	✓			
Analog Output						✓				
Control					✓					
RF Switching										

Specification Conditions

This document contains specifications and supplemental information for the DAQ6510. Specifications are the standards against which the DAQ6510 is tested. Upon leaving the factory, the DAQ6510 meets these specifications. Supplemental and typical values are nonwarranted, apply at 23 °C, and are provided solely as useful information. Measurement accuracies are specified for plug-in module user input terminals and DAQ6510 front input terminals and include conversion error for thermocouple, thermistor, and RTD measurements. Additional switching module errors are included in the Characteristics section under each function.

Measurement Conditions Include:

- After a 30-minute warmup period
- 1 PLC or 5 PLC measurement rate; for NPLC settings less than 1 PLC, add appropriate noise error from Measurement Noise table under each function
- Autozero enabled
- Calibration period: one year (recommended) or two years. Calibration period may vary depending on customer requirements
- 24-hour accuracy specification is relative to calibrator accuracy
- The communication accessory slot cover or an optional KTTI interface card is properly installed on the rear of the unit

Definitions:

- **T_{CAL}**: The temperature at which the instrument was calibrated (23°C for factory calibration)
- **Temperature coefficient**: Additional uncertainty added for each °C outside T_{CAL} ±5°C
- **Power Line Cycle (PLC)**: 16.67 ms at 60 Hz and 20 ms at 50 Hz or 400 Hz line frequency; frequency automatically sensed at power up

DC Voltage

DC Voltage Accuracy ±(% of reading + % of range)

Range	Resolution	Input Impedance	24 Hours T _{CAL} ±1°C	90 Days T _{CAL} ±5°C	1 Year T _{CAL} ±5°C	2 Years T _{CAL} ±5°C	Temperature Coefficient
100 mV	100 nV	>10 GΩ or 10 MΩ ±1%	0.0015 + 0.0030	0.0025 + 0.0035	0.0030 + 0.0035	0.0035 + 0.0035	0.0001 + 0.0005
1 V	1 μV	>10 GΩ or 10 MΩ ±1%	0.0015 + 0.0006	0.0020 + 0.0006	0.0025 + 0.0006	0.0030 + 0.0006	0.0001 + 0.0001
10 V	10 μV	>10 GΩ or 10 MΩ ±1%	0.0010 + 0.0004	0.0020 + 0.0005	0.0025 + 0.0005	0.0030 + 0.0005	0.0001 + 0.0001
100 V	100 μV	10 MΩ ±1%	0.0015 + 0.0006	0.0035 + 0.0006	0.0040 + 0.0006	0.0050 + 0.0006	0.0006 + 0.0001
1000 V ¹	1 mV	10 MΩ ±1%	0.0020 + 0.0006	0.0035 + 0.0006	0.0040 + 0.0006	0.0050 + 0.0006	0.0006 + 0.0001

Measurement Noise Characteristics and Rejection Ratios

Measurement Rate in NPLCs	Digits	DCV RMS Noise Uncertainty (in % of range + fixed base) ²	NMRR ³	CMRR ³
5 ⁴	6.5	0	100 dB	140 dB
5		0	60 dB	140 dB
1 ⁴		0	90 dB	140 dB
1		0	60 dB	140 dB
0.1 ⁴		0.00015 + 1 μV	40 dB	120 dB
0.1	5.5	0.00015 + 4 μV	—	120 dB
0.01		0.00030 + 6 μV	—	80 dB
0.0005		4.5	0.00500 + 40 μV	—

DC Voltage Characteristics

Overrange	20% on 100 mV, 1 V, 10 V, and 100 V ranges. 1% on 1000 V range.
ADC Linearity (10 V range)	0.0001% of reading + 0.0001% of range
Input Impedance	100 mV to 10 V Ranges: Selectable, >10 GΩ or 10 MΩ with <400 pF. 100 V to 1000 V Ranges: 10 MΩ ±1% in parallel with <400 pF
Input Bias Current	<50 pA at 23°C
Common Mode Current	<600 nA peak-peak at 50 Hz or 60 Hz
Earth Isolation	500 V _{peak} >10 GΩ and <300 pF any terminal to chassis
Common Mode Voltage	500 V _{peak} LO terminal to chassis maximum
Autozero Off Error	Add ±(0.0002% of range + 3 μV) within ±1°C and ≤10 minutes since last autozero. Add ±(0.0010% of range + 10 μV) within ±5°C and ≤60 minutes since last autozero
Input Protection	Front-panel DAQ input: Input HI 1010 V, Sense HI (SHI) and Sense LO (SLO) 350 V referenced to LO Rear-panel DAQ input through the plug-in modules: 600 V _{PEAK} all ranges (note this level exceeds the maximum input signal for modules: see the table below for module levels)

Plug-In Module Additional Uncertainties and Maximum Input Signal Levels

Plug-In Module	Add the Following Uncertainty	Maximum Input Signal Level
7000, 7002, 7008	1 μV	300 V for 7700, 7702, and 7708
7701, 7703, 7707	6 μV	300 V for 7703 and 7707
		150 V for 7701
150 V for 7701	3 μV	300 V for 7706 and 7709
		60 V for 7710

Notes

- For each additional volt over ±500 V, add 0.02 mV of uncertainty.
- Noise values apply to terminals using a low-thermal short for 50 Hz and 60 Hz operation only. Measurements through a card may introduce additional noise.
- NMRR for line frequency is ±0.1%. For DC common mode and 1 kΩ, unbalance on LO terminal, rejection of AC common mode signals is >80 dB for a line frequency ±0.1%.
- Line sync on.

Resistance

Resistance Accuracy \pm (% of reading + % of range)⁵

Range	Resolution	Test Current ($\pm 5\%$)	Open Circuit Voltage ($\pm 5\%$)	24 Hours $T_{CAL} \pm 1^\circ C$	90 Days $T_{CAL} \pm 5^\circ C$	1 Year $T_{CAL} \pm 5^\circ C$	2 Years $T_{CAL} \pm 5^\circ C$	Temperature Coefficient
1 Ω ⁶	1 $\mu\Omega$	10 mA	12.5 V	0.0080 + 0.0200	0.0080 + 0.0200	0.0085 + 0.0200	0.0100 + 0.0200	0.0006 + 0.0010
10 Ω ⁶	10 $\mu\Omega$	10 mA	12.5 V	0.0020 + 0.0020	0.0080 + 0.0020	0.0085 + 0.0020	0.0100 + 0.0020	0.0006 + 0.0001
100 Ω	100 $\mu\Omega$	1 mA	9.2 V	0.0020 + 0.0020	0.0075 + 0.0020	0.0085 + 0.0020	0.0100 + 0.0020	0.0006 + 0.0001
1 k Ω	1 m Ω	1 mA	9.2 V	0.0020 + 0.0006	0.0065 + 0.0006	0.0075 + 0.0006	0.0090 + 0.0006	0.0006 + 0.0001
10 k Ω	10 m Ω	100 μA	12.7 V	0.0020 + 0.0006	0.0065 + 0.0006	0.0075 + 0.0006	0.0090 + 0.0006	0.0006 + 0.0001
100 k Ω	100 m Ω	10 μA	12.5 V	0.0020 + 0.0006	0.0070 + 0.0010	0.0075 + 0.0010	0.0100 + 0.0010	0.0006 + 0.0001
1 M Ω	1 Ω	10 μA	12.5 V	0.0020 + 0.0006	0.0075 + 0.0006	0.0100 + 0.0006	0.0120 + 0.0006	0.0006 + 0.0001
10 M Ω ⁷	10 Ω	0.7 μA 10 M Ω	7.1 V	0.0150 + 0.0006	0.0200 + 0.0010	0.0400 + 0.0010	0.0450 + 0.0010	0.0105 + 0.0001
100 M Ω ⁷	100 Ω	0.7 μA 10 M Ω	7.1 V	0.0800 + 0.0030	0.2000 + 0.0030	0.2000 + 0.0030	0.2500 + 0.0030	0.047 + 0.0001

Resistance Measurement Noise Characteristics⁸

Measurement Rate in NPLC	Digits	2-wire RMS Noise Uncertainty (in % of range + fixed base)	4-wire RMS Noise Uncertainty, Offset Compensation OFF (in % of range + fixed base) ⁹	4-wire RMS noise uncertainty, offset compensation ON (in % of range + fixed base) ⁹
5	6.5	0	0	0
1		0	0	0
0.1 ¹⁰		0.00015 + 0.10 m Ω	0.00020 + 0.20 m Ω	0.00030 + 0.25 m Ω
0.1	5.5	0.00050 + 0.35 m Ω	0.00180 + 2.00 m Ω	0.00350 + 3.50 m Ω
0.01		0.00070 + 0.50 m Ω	0.00260 + 2.50 m Ω	0.00500 + 4.00 m Ω
0.0005		4.5	0.00650 + 3.50 m Ω	0.01000 + 7.00 m Ω

Resistance Characteristics

Overrange	20% on all ranges
Autozero Off Error	Add \pm (0.0005% of range + 5 m Ω) within $\pm 1^\circ C$ and ≤ 10 minutes since last autozero Add \pm (0.0020% of range + 10 m Ω) within $\pm 5^\circ C$ and ≤ 60 minutes since last autozero
Offset Compensation	Selectable on 1 Ω , 10 Ω , 100 Ω , 1 k Ω , and 10 k Ω ranges, 4-wire mode only
Maximum 4-wire Lead Resistance	5 Ω per lead for 1 Ω range 10% of range per lead for 10 Ω , 100 Ω , 1 k Ω , and 10 k Ω ranges 1 k Ω per lead for 100 k Ω , 1 M Ω , 10 M Ω , and 100 M Ω
Open Lead Detector	Selectable on all ranges, 4-wire mode only; default is off.
Input Protection	Front-panel DAQ input: Input HI 1010 V, Sense HI (SHI) and Sense LO (SLO) 350 V referenced to LO Rear-panel DAQ input through the plug-in modules: 600 V _{PEAK} all ranges (note this level exceeds the maximum input signal for modules: see maximum input signal levels for 7700 series plug-in modules listed in DC Voltage Characteristics or separately supplied module specifications)

Switching Module Additional Contact Resistance

See Plug-in Switching Module Data Sheet

Plug-In Switching Module Additional Uncertainties

Module	Add the following to % of reading accuracy				
	10 k Ω	100 k Ω	1 M Ω	10 M Ω	100 M Ω
7701, 7703, 7707, 7709	0.001	0.01	0.1	1	10
7706, 7708	0.0005	0.005	0.05	0.5	5
7700, 7702	—	—	—	0.022	0.22
7710	% of reading error				
	0.0011	0.011	0.11	1.1	11
	Temperature Coefficient (% reading/$^\circ C$)				
	0.00003	0.0003	0.003	0.03	0.3

Notes

- Specifications are for 2- and 4-wire resistance. For 2-wire, use relative offset, and add 100 m Ω of additional uncertainty. For 4-wire, turn offset compensation on for ≤ 0 k Ω and off for > 10 k Ω . The 1 Ω range is for 4-wire only.
- Requires a 10-reading digital filter at 1 PLC or 2-reading digital filter at 5 PLC.
- Specified for $< 10\%$ lead-resistance mismatch at HI and LO.
- Applies for 1 Ω through 1 M Ω ranges. For 100 Ω range, multiple the listed values by five. Noise values apply to terminals using a low-thermal short for 50 Hz and 60 Hz operation only. Measurements through a switching module may introduce additional noise.
- Open lead detection off.
- Line sync on.

DC Current

DC Current Accuracy \pm (% of reading + % of range)

Range	Resolution	Burden Voltage	24 Hours $T_{CAL} \pm 1^{\circ}C$	90 Days $T_{CAL} \pm 5^{\circ}C$	1 Year $T_{CAL} \pm 5^{\circ}C$	2 Years $T_{CAL} \pm 5^{\circ}C$	Temperature Coefficient
10 μA ¹¹	10 pA	< 0.13 V	0.007 + 0.002	0.035 + 0.005	0.045 + 0.005	0.055 + 0.005	0.0030 + 0.0006
100 μA	100 pA	< 0.14 V	0.010 + 0.002	0.035 + 0.005	0.045 + 0.005	0.055 + 0.005	0.0020 + 0.0005
1 mA	1 nA	< 0.17 V	0.007 + 0.006	0.035 + 0.005	0.045 + 0.005	0.055 + 0.005	0.0020 + 0.0005
10 mA	10 nA	< 0.17 V	0.006 + 0.003	0.018 + 0.005	0.020 + 0.005	0.025 + 0.005	0.0015 + 0.0005
20 mA ¹²	10 nA	< 0.05 V	0.010 + 0.150	0.015 + 0.025	0.020 + 0.025	0.025 + 0.025	0.0015 + 0.0025
100 mA	100 nA	< 0.20 V	0.010 + 0.003	0.015 + 0.005	0.020 + 0.005	0.025 + 0.005	0.0015 + 0.0005
1 A	1 μA	< 0.55 V ¹³	0.020 + 0.004	0.030 + 0.005	0.040 + 0.005	0.050 + 0.005	0.0030 + 0.0005
3 A	1 μA	< 1.70 V ¹³	0.030 + 0.004	0.040 + 0.004	0.050 + 0.004	0.060 + 0.004	0.0030 + 0.0005

DC Current Characteristics

Overrange	20% on 10 μA , 100 μA , 1 mA, 10 mA, 100 mA, and 1 A ranges 1% on 3 A range														
Front-Panel Input Protection	Externally accessible 3 A, 250 V fast-acting fuse, 5 x 20 mm: Keithley replacement part number FU-99-1														
Plug-in Module Input Protection	Fuse provided in 7700 and 7702 plug-in modules; PCB-mounted 3 A, 250 V, fast-acting fuse														
Autozero Off Error	Add $\pm 0.004\%$ of range within $\pm 1^{\circ}C$ and ≤ 10 minutes since last autozero Add $\pm 0.015\%$ of range within $\pm 5^{\circ}C$ and ≤ 60 minutes since last autozero														
Nominal Shunt Resistance¹⁴	<table border="1"> <thead> <tr> <th>10 μA</th> <th>100 μA</th> <th>1 mA</th> <th>10 mA</th> <th>100 mA</th> <th>1 A</th> <th>3 A</th> </tr> </thead> <tbody> <tr> <td>10 kΩ</td> <td>1 kΩ</td> <td>100 Ω</td> <td>10 Ω</td> <td>1 Ω</td> <td>100 mΩ</td> <td>100 mΩ</td> </tr> </tbody> </table>	10 μA	100 μA	1 mA	10 mA	100 mA	1 A	3 A	10 k Ω	1 k Ω	100 Ω	10 Ω	1 Ω	100 m Ω	100 m Ω
10 μA	100 μA	1 mA	10 mA	100 mA	1 A	3 A									
10 k Ω	1 k Ω	100 Ω	10 Ω	1 Ω	100 m Ω	100 m Ω									

DC Current Measurement Noise Characteristics¹⁵

Measurement Rate in NPLC	Digits	DC Current RMS Noise Uncertainty (% of range + fixed base)
5	6.5	0
1		0
0.1 ¹⁶		0.0009 + 10.0 pA
0.1	5.5	0.0015 + 5.0 nA
0.01		0.0030 + 5.0 nA
0.0005		0.0200 + 5.0 nA

Notes

11. Specifications apply to front-panel inputs only.
12. 20 mA range for 27xx emulation mode only.
13. Add 1.5 V when using with plug-in modules.
14. Guaranteed by design.
15. Noise values apply to open terminals for 50 Hz and 60 Hz operation only. Measurements through a card may introduce additional noise.
16. Line sync on.

Temperature

Thermocouple Accuracy $\pm^{\circ}\text{C}^{17}$

Type	Resolution	Range	2 Year Accuracy $T_{\text{CAL}} \pm 5^{\circ}\text{C}$; all uncertainties in $^{\circ}\text{C}$						Temperature Coefficient in $^{\circ}\text{C}/^{\circ}\text{C}$
			Simulated or External CJC			Internal CJC (on module)			
			Front Terminals, 7700, 7702, 7708	7706, 7709, 7710	7701, 7703, 7707	7700, 7708	7706	7710	
J	0.001 $^{\circ}\text{C}$	0 $^{\circ}\text{C}$ to 760 $^{\circ}\text{C}$	0.20	0.20	0.20	1.00	1.00	1.30	0.03
		-200 $^{\circ}\text{C}$ to <0 $^{\circ}\text{C}$	0.20	0.20	0.40	1.50	1.90	3.00	0.03
K	0.001 $^{\circ}\text{C}$	0 $^{\circ}\text{C}$ to 1372 $^{\circ}\text{C}$	0.20	0.20	0.30	1.00	1.00	1.00	0.03
		-200 $^{\circ}\text{C}$ to <0 $^{\circ}\text{C}$	0.30	0.30	0.50	1.70	2.00	2.00	0.03
N	0.001 $^{\circ}\text{C}$	0 $^{\circ}\text{C}$ to 1300 $^{\circ}\text{C}$	0.20	0.20	0.30	1.00	1.00	1.40	0.03
		-200 $^{\circ}\text{C}$ to <0 $^{\circ}\text{C}$	0.50	0.60	0.80	1.80	2.30	3.60	0.03
T	0.001 $^{\circ}\text{C}$	0 $^{\circ}\text{C}$ to 400 $^{\circ}\text{C}$	0.20	0.20	0.20	1.00	1.00	1.50	0.03
		-200 $^{\circ}\text{C}$ to <0 $^{\circ}\text{C}$	0.30	0.30	0.50	1.60	2.00	3.50	0.03
E	0.001 $^{\circ}\text{C}$	0 $^{\circ}\text{C}$ to 1000 $^{\circ}\text{C}$	0.20	0.20	0.20	1.00	1.00	1.20	0.03
		-200 $^{\circ}\text{C}$ to <0 $^{\circ}\text{C}$	0.20	0.30	0.30	1.50	1.80	3.00	0.03
R	0.010 $^{\circ}\text{C}$	600 $^{\circ}\text{C}$ to 1768 $^{\circ}\text{C}$	0.40	0.50	0.70	1.00	1.00	1.20	0.03
		0 $^{\circ}\text{C}$ to <600 $^{\circ}\text{C}$	0.80	1.00	1.50	1.50	1.60	2.20	0.03
S	0.010 $^{\circ}\text{C}$	600 $^{\circ}\text{C}$ to 1768 $^{\circ}\text{C}$	0.40	0.50	0.70	1.00	1.00	1.20	0.03
		0 $^{\circ}\text{C}$ to <600 $^{\circ}\text{C}$	0.80	1.00	1.50	1.30	1.60	2.20	0.03
B	0.010 $^{\circ}\text{C}$	1100 $^{\circ}\text{C}$ to 1820 $^{\circ}\text{C}$	0.40	0.50	0.80	1.00	1.00	1.00	0.03
		350 $^{\circ}\text{C}$ to <1100 $^{\circ}\text{C}$	1.20	1.50	2.20	1.10	1.40	1.50	0.03

Resistance Temperature Detector (RTD) Accuracy $\pm^{\circ}\text{C}$

Types: 100 Ω platinum PT100, D100, F100, PT385, and PT3916 or user-configurable 0 Ω to 10 k Ω

Measurement Method	Resolution	Range	2 Year Accuracy $T_{\text{CAL}} \pm 5^{\circ}\text{C}$	Temperature Coefficient in $^{\circ}\text{C}/^{\circ}\text{C}$
2-wire ¹⁸	0.01 $^{\circ}\text{C}$	-200 $^{\circ}$ to 850 $^{\circ}\text{C}$	0.80	0.003
3-wire ¹⁹	0.01 $^{\circ}\text{C}$	-200 $^{\circ}$ to 600 $^{\circ}\text{C}$	0.35	0.003
		>600 $^{\circ}$ to 850 $^{\circ}\text{C}$	0.37	0.003
4-wire	0.01 $^{\circ}\text{C}$	-200 $^{\circ}$ to 600 $^{\circ}\text{C}$	0.06	0.003
		>600 $^{\circ}$ to 850 $^{\circ}\text{C}$	0.12	0.003

Thermistor Accuracy $\pm^{\circ}\text{C}$

Types: 2.2 k Ω , 5 k Ω , and 10 k Ω

Measurement Method	Resolution	Range	2 Year Accuracy $T_{\text{CAL}} \pm 5^{\circ}\text{C}$	Temperature Coefficient in $^{\circ}\text{C}/^{\circ}\text{C}$
2-wire	0.01 $^{\circ}\text{C}$	-80 $^{\circ}$ to 150 $^{\circ}\text{C}$	0.08	0.002

For readings >70 $^{\circ}\text{C}$, add this additional uncertainty per Ω of lead, channel, and contact resistance

Thermistor Type	Common Model Number	70 $^{\circ}$ to 100 $^{\circ}\text{C}$	>100 $^{\circ}$ to 150 $^{\circ}\text{C}$
2.2 k Ω	44004	0.22 $^{\circ}\text{C}$ per Ω	1.11 $^{\circ}\text{C}$ per Ω
5 k Ω	44007	0.10 $^{\circ}\text{C}$ per Ω	0.46 $^{\circ}\text{C}$ per Ω
10 k Ω	44006	0.04 $^{\circ}\text{C}$ per Ω	0.19 $^{\circ}\text{C}$ per Ω

Notes

17. Accuracy excludes probe errors.

18. Specifications do not include errors that may arise from user's cable or terminal resistance.

19. 3-wire RTD accuracy is for <0.1 Ω lead-resistance mismatch for input HI and LO. Add 0.25 $^{\circ}\text{C}$ per 0.1 Ω of HI-LO resistance mismatch.

Temperature Characteristics

Thermocouple Conversion	ITS-90
Thermocouple Reference Junction	External (CJC on 2001-TCSCAN or user-provided with 2000-SCAN) or simulated (fixed)
Open Thermocouple Detection	Selectable per channel (open >130 kΩ; default on.
Earth Isolation	500 V _{PEAK} > 0 GΩ and <300 pF any terminal to chassis

AC Voltage

AC Voltage Accuracy ±(% of reading + % of range)¹⁹

Range	Resolution	Calibration Cycle	3 Hz to 5 Hz	5 Hz to 10 Hz	10 Hz to 20 kHz	20 kHz to 50 kHz	50 kHz to 100 kHz	100 kHz to 300 kHz
100 mV	100 nV	24 hours	1.00 + 0.02	0.35 + 0.02	0.04 + 0.02	0.10 + 0.04	0.55 + 0.08	4.00 + 0.50
1 V	1 μV	90 days	1.00 + 0.03	0.35 + 0.03	0.05 + 0.03	0.11 + 0.05	0.60 + 0.08	4.00 + 0.50
10 V	10 μV		1 year	1.00 + 0.03	0.35 + 0.03	0.06 + 0.03	0.12 + 0.05	0.60 + 0.08
100 V	100 μV	2 years	1.00 + 0.03	0.35 + 0.03	0.07 + 0.03	0.13 + 0.05	0.60 + 0.08	4.00 + 0.50
750 V	100 μV		0.100 + 0.003	0.035 + 0.003	0.005 + 0.003	0.011 + 0.005	0.060 + 0.008	0.200 + 0.020
Temperature Coefficient			0.100 + 0.003	0.035 + 0.003	0.005 + 0.003	0.011 + 0.005	0.060 + 0.008	0.200 + 0.020

AC Voltage Characteristics

Overrange (voltages in V_{RMS})	20% on 100 mV, 1 V, 10 V, and 100 V ranges. 0% for 750 V range.
AC Measurement Method	AC-coupled digital sampling with anti-alias filter
Crest Factor (excludes sine wave)	Crest factors of up to 3:1 at full-scale input or 10:1 maximum, whichever is greater Autorange selects optimum range for crest factor up to 10:1 Accuracy specifications apply to all crest factors and are limited to a product of (crest factor) × (fundamental frequency) ≤ 3 kHz
Volt*Hertz Product	≤ 8 × 10 ⁷ V*Hz ²¹
Common Mode Rejection Ratio	>70 dB, for 1 kΩ unbalance in LO lead
Detector Bandwidth	Setting of 3 Hz, 30 Hz, or 300 Hz sets maximum measurement aperture of 200 ms, 20 ms, or 2 ms, respectively; only signals with frequency greater than the detector bandwidth are measured.
Input Impedance	1.1 MΩ ±2%, in parallel with <100 pF
Input Protection	Front-panel input: 1100 V _{PEAK} or 400 VDC on all ranges Rear-panel input through the plug-in modules: 600 V _{PEAK} on all ranges (note this level exceeds the maximum input signal for modules; see Maximum Input Signal Levels for 7700 Series plug-in modules listed below.
Maximum DCV	400 V on any ACV range
ACV Frequency	Frequency reading automatically returned in reading buffer when in full buffer mode. Frequency readings are specified as in the frequency and period table.

Plug-in Module Maximum Input Signal Levels

Module	Maximum Input Signal Level
7700, 7702, 7703, 7706, 7707, 7708, 7709	300 V _{RMS} / 425 V _{PEAK}
7701	150 V _{RMS} / 212 V _{PEAK}
7710	42 V _{RMS} / 60 V _{PEAK}

Notes

20. Specifications are for sine wave inputs >5% of range.
21. Guaranteed by design.

AC Current

AC Current Accuracy \pm (% of reading + % of range)²²

Range	Resolution	Burden Voltage	Frequency	24 Hours $T_{CAL} \pm 1^{\circ}C$	90 Days $T_{CAL} \pm 5^{\circ}C$	1 Year $T_{CAL} \pm 5^{\circ}C$	2 Years $T_{CAL} \pm 5^{\circ}C$	Temperature Coefficient
100 μA ²³	100 pA	<0.14 V	3 Hz – 1 kHz	0.10 + 0.07	0.10 + 0.07	0.10 + 0.07	0.10 + 0.07	0.015 + 0.010
			>1 kHz – 10 kHz ²⁴	0.15 + 0.07	0.15 + 0.07	0.15 + 0.07	0.15 + 0.07	0.030 + 0.010
1 mA	1 nA	<0.17 V	3 Hz – 5 kHz	0.10 + 0.04	0.10 + 0.04	0.10 + 0.04	0.10 + 0.04	0.015 + 0.006
			>5 kHz – 10 kHz ²⁴	0.10 + 0.04	0.10 + 0.04	0.10 + 0.04	0.10 + 0.04	0.030 + 0.006
10 mA	10 nA	<0.17 V	3 Hz – 5 kHz	0.10 + 0.04	0.10 + 0.04	0.10 + 0.04	0.10 + 0.04	0.015 + 0.006
			>5 kHz – 10 kHz ²⁴	0.10 + 0.04	0.10 + 0.04	0.10 + 0.04	0.10 + 0.04	0.030 + 0.006
100 mA	100 nA	<0.20 V	3 Hz – 5 kHz	0.10 + 0.04	0.10 + 0.04	0.10 + 0.04	0.10 + 0.04	0.015 + 0.006
			>5 kHz – 10 kHz ²⁴	0.10 + 0.04	0.10 + 0.04	0.10 + 0.04	0.10 + 0.04	0.030 + 0.006
1 A	1 μA	<0.75 V ²⁵	3 Hz – 5 kHz ²⁶	0.10 + 0.04	0.10 + 0.04	0.10 + 0.04	0.10 + 0.04	0.015 + 0.006
			>5 kHz – 10 kHz ²⁴	0.15 + 0.06	0.15 + 0.06	0.15 + 0.06	0.15 + 0.06	0.030 + 0.006
3 A	1 μA	<1.70 V ²⁵	3 Hz – 5 kHz ²⁶	0.15 + 0.06	0.15 + 0.06	0.15 + 0.06	0.15 + 0.06	0.015 + 0.006
			>5 kHz – 10 kHz ²⁴	0.15 + 0.06	0.15 + 0.06	0.15 + 0.06	0.15 + 0.06	0.030 + 0.006

AC Current Characteristics

Overrange 20% on 100 μA , 1 mA, 10 mA, 100 mA, and 1 A ranges
1% on 3 A range

AC Measurement Type AC-coupled true RMS; measures the AC component of the input
Digital sampling with anti-alias filter.

Input Protection See DC Current Characteristics

Crest Factor²⁷ (excludes sine wave) 10:1 maximum crest factor (1.75:1 at full-scale)
Autorange selects optimum range for crest factor up to 10:1
Accuracy specifications apply to all crest factors less than 5 and are limited to the product of (crest factor) \times (fundamental frequency) \leq 200 Hz

ACI Frequency Frequency readings are automatically returned in the reading buffer when in full buffer mode.
Frequency values are typical.

Nominal Shunt Resistance²⁸

	100 μA	1 mA	10 mA	100 mA	1 A	3 A
	1 k Ω	100 Ω	10 Ω	1 Ω	100 m Ω	100 m Ω

Notes

22. Specifications are for sine wave inputs $> 5\%$ of range and $> 10 \mu A_{RMS}$.

23. The 100 μA range is only specified for front-panel inputs.

24. Typical performance for the indicated frequency ranges.

25. Add 1.5 V for the 1 A and 3 A ranges when used with a plug-in module.

26. For signals of < 5 Hz, add 0.2% of reading uncertainty.

27. 100 μA range is specified only for crest factors < 3 .

28. Guaranteed by design.

Frequency and Period

Frequency and Period Accuracy ± (% of reading)²⁹

Range	Resolution	Frequency	Period	2 Year Accuracy T _{CAL} ±5°C	Temperature Coefficient in°C/°C
100 mV to 750 V (For signals >5% of range and >10 mV _{RMS})	0.0001% ppm of reading	3 Hz to 10 Hz	333 ms to 100 ms	0.100	0.0002
		>10 Hz to 100 Hz	<100 ms to 10 ms	0.030	0.0002
		>100 Hz to 1 kHz	<10 ms to 1 ms	0.010	0.0002
		>1 kHz to 300 kHz	<1 ms to 3.3 μs	0.009	0.0002
		Square Wave³⁰			0.008

Frequency and Period Characteristics

Measurement Method	Reciprocal-counting technique; measurement is AC-coupled using AC measurement functions.
Voltage Ranges	100 mV _{RMS} full scale to 750 V _{RMS} ; auto or manual ranging.
Gate Time	User definable from 2 ms to 273 ms (default 200 ms)

Continuity

Continuity Accuracy 2-Wire ±(% of reading + % of range)³¹

Range	Resolution	Test Current	Open Circuit Voltage (±5%)	2 Year Accuracy T _{CAL} ±5°C	Temperature Coefficient
1 kΩ	100 mΩ	1 mA	9.2 V	0.010 + 0.010	0.0006 + 0.0001

Capacitance

Capacitance Accuracy ±(% of reading + % of range)³²

Range	Resolution	Charge Current (±5%) ³³	2 Year Accuracy T _{CAL} ±5°C	Temperature Coefficient
1 nF ³⁴	0.1 pF	1 μA	0.80 + 0.50	0.05 + 0.05
10 nF	1 pF	10 μA	0.40 + 0.10	0.05 + 0.01
100 nF	10 pF	100 μA	0.40 + 0.10	0.05 + 0.01
1 μF	0.1 nF	100 μA	0.40 + 0.10	0.05 + 0.01
10 μF	1 nF	1 mA	0.40 + 0.10	0.05 + 0.01
100 μF	10 nF	1 mA	0.40 + 0.10	0.05 + 0.01

Capacitance Characteristics

Overrange	20% on all ranges.
Measurement Method	Constant current slope measurement.
Maximum Voltage and Voltage Clamp	For all devices: Clamped by hardware to <3 V.

Notes

29. Specifications apply for sine wave input with detector bandwidth of 3 Hz. For a detector bandwidth of 30 Hz, add 100 mHz uncertainty.
For a detector bandwidth of 300 Hz, add 1 Hz uncertainty.
30. Used for square waves with amplitude > 10% of range and 10 Hz to 300 kHz.
31. Does not include user's lead-resistance or plug-in module contact resistance.
32. Accuracies specified for cable, channel, and other stray connector capacitance properly zeroed with the REL function.
33. Discharge current limited to < 10 mA.
34. Specifications apply to front-panel inputs only.

Diode

Diode Voltage Accuracy \pm (% of reading + additional uncertainty)³⁵

Voltage Measure Range	Resolution	Maximum Voltage Measurement	Test Current ($\pm 5\%$)	2 Year Accuracy $T_{CAL} \pm 5^{\circ}C$	Temperature Coefficient
10 V	10 μV	12 V	10 μA	0.0045 + 60.0 μV	0.0008 + 10 μV
		10 V	100 μA	0.0045 + 80.0 μV	0.0008 + 10 μV
		7 V	1 mA	0.0045 + 170.0 μV	0.0010 + 10 μV
		7 V	10 mA	0.0045 + 1.1 mV	0.0010 + 10 μV

Digitize

Digitize DC Voltage Accuracy \pm (% of reading + % of range)³⁶

Range	Resolution	Input Impedance	2 Year Accuracy $T_{CAL} \pm 5^{\circ}C$	Temperature Coefficient
100 mV	10 μV	>10 G Ω or 10 M Ω $\pm 1\%$	0.040 + 0.020	0.0025 + 0.0030
1 V	100 μV	>10 G Ω or 10 M Ω $\pm 1\%$	0.030 + 0.010	0.0025 + 0.0010
10 V	1 mV	>10 G Ω or 10 M Ω $\pm 1\%$	0.030 + 0.010	0.0025 + 0.0010
100 V	10 mV	10 M Ω $\pm 1\%$	0.030 + 0.010	0.0025 + 0.0010
1000 V	100 mV	10 M Ω $\pm 1\%$	0.030 + 0.010	0.0025 + 0.0010

Digitize DC Current Accuracy \pm (% of reading + % of range)³⁶

Range	Resolution	Burden Voltage	2 Year Accuracy $T_{CAL} \pm 5^{\circ}C$	Temperature Coefficient
100 μA	10 nA	<0.14 V	0.07 + 0.05	0.0030 + 0.0035
1 mA	100 nA	<0.17 V	0.07 + 0.03	0.0030 + 0.0035
10 mA	1 μA	<0.17 V	0.05 + 0.03	0.0030 + 0.0035
100 mA	10 μA	<0.20 V	0.05 + 0.03	0.0020 + 0.0035
1 A	100 μA	<0.55 V ³⁷	0.07 + 0.03	0.0040 + 0.0035
3 A	100 μA	<1.70 V ³⁷	0.09 + 0.04	0.0040 + 0.0035

Notes

35. Specifications apply to the front-panel inputs, only. Specifications do not include errors that may arise from user's cable or connection resistance.

36. DC accuracy specified with 1000 samples per second, 100-reading digital filter.

37. Add 1.5 V for 1 A and 3 A ranges when used with a plug-in module.

Typical Digitize Signal Characteristics

Typical performance for these conditions: Sample rate 1 MS per s; sine wave input $V_{PEAK} = -1$ dB full-scale of range

Function: Range	Spur-free Range SFDR (1 kHz / 10 kHz / 50 kHz)	THD + Noise SNDR (1 kHz / 10 kHz / 50 kHz)	Bandwidth (-3 dB, 5%)	Effective Number of Bits (1 kHz/10 kHz/50 kHz)
DCV: 100 mV	75 / 70 / 50	65 / 60 / 50	210 kHz	9 / 9 / 7
DCV: 1 V	95 / 90 / 75	80 / 80 / 75	210 kHz	12 / 12 / 11
DCV: 10 V	95 / 80 / 70	90 / 80 / 70	440 kHz	13 / 12 / 10
DCV: 100 V	50 / 35 / 25	50 / 40 / 30	17 kHz	10 / 8 / 7
DCV: 1000 V	50 / 35 / 25	50 / 40 / 30	17 kHz	13 / 11 / 10
DCI: 100 μA	80 / 65 / 45	70 / 65 / 45	430 kHz	12 / 10 / 8
DCI: 1 mA	80 / 65 / 45	70 / 65 / 45	570 kHz	12 / 10 / 8
DCI: 10 mA	80 / 65 / 45	70 / 65 / 45	230 kHz	12 / 10 / 8
DCI: 100 mA	80 / 65 / 45	70 / 65 / 45	340 kHz	12 / 10 / 8
DCI: 1 A	70 / 50 / 40	65 / 50 / 40	25 kHz	11 / 8 / 7
DCI: 3 A	70 / 50 / 40	65 / 50 / 40	25 kHz	11 / 8 / 7

Digitizing Additional Characteristics

Maximum Resolution	16 bits
Measurement Input Coupling	DC coupled
Sampling Rate	Programmable 1 kS through 1 MS/s
Minimum Record Time	1 μs
Maximum Record Length (Volatile)	7 million with standard buffer (includes channel and formatting information)

DC Voltage Ratio

DC Voltage Ratio Calculation³⁸

Method	Measurement
Channel Ratio (through rear input plug-in module)	$\text{Channel Ratio} = \frac{\text{Channel A}}{\text{Channel B}}$ $\text{Accuracy} = (\text{Accuracy of channel A measure range} + \text{Accuracy of channel B measure range}) \times \text{Channel ratio}$
Channel Average (through rear input plug-in module)	$\text{Channel Average} = \frac{\text{Channel A} + \text{Channel B}}{2}$ $\text{Accuracy} = \text{Accuracy of channel A measure range} + \text{Accuracy of paired channel B measure range}$
DCV Input Ratio (HI-LO/SHI-SLO) ^{39, 40}	$\text{Ratio} = \frac{\text{HI signal}}{\text{SHI signal} - \text{SLO signal}}$ $\text{Accuracy} = \left(\frac{\text{HI range}}{\text{HI signal}} \times \text{DCV\% of range accuracy} + \frac{10 \text{ V}}{\text{SHI signal} - \text{SLO signal}} \times 0.0008\% \right) \times \text{Ratio}$

Notes

38. See DC Voltage Accuracy. SHI and SLO: 10 V range only. SHI and SLO (sense) terminals referenced to LO input. Maximum voltage referenced to LO 12 V.

39. Sense terminals on inputs are limited to 10 V range during ratio measurement. Add 0.0015% + 0.0005% per °C temperature coefficient to DCV percent of range accuracy when using the 100 V or 1000 V range on the input terminals.

40. Specified for front inputs only.

System Specifications

Typical Single-Channel Rates, DC Functions^{41, 42}

60 Hz (50 Hz) Operation

NPLCs	Functions: DCV (10 V) 2-wire Ω (≤ 10 k Ω), DCI (1 mA)		Functions: 4-wire Ω (≤ 1 k Ω) 4-wire and 3-wire RTD		Function: Thermistor or Thermocouple	
	Measurements (readings per second) ⁴³					
	Buffer	Computer	Buffer	Computer	Buffer	Computer
5	12 (10)	11 (9)	5 (4)	5 (4)	12 (10)	11 (9)
1	59 (48)	58 (48)	28 (23)	28 (23)	59 (49)	57 (48)
0.1	584 (490)	440 (380)	180 (160)	170 (150)	580 (480)	440 (380)
0.01	4900 (4100)	4800 (4100)	400 (390)	400 (390)	4800 (4100)	4700 (4000)
0.0005	20600 (20600)	19800 (19800)	460 (460)	460 (460)	21000 (21000)	20300 (20300)

Typical Single-Channel Reading Rates, AC Functions⁴¹

60 Hz (50 Hz) Operation

Function: ACV, ACI	Function: Frequency, Period	Measurements (readings per second)
Detector Bandwidth	Aperture	Buffer or Computer
3 Hz	200 ms	1
30 Hz	20 ms	10
300 Hz	2 ms	100

Scanning/Multiple Channels (with optional scan cards)⁴⁴

Typical Scanning Measurement Rates	Measurements Into Buffer/Computer (channels per second)
Scanning DCV or 2-wire Ω	>90 with 7700 plug-in module >450 with 7703 plug-in module >900 with 7710 plug-in module
Scanning Thermocouple, Thermistor, or 2-wire RTD	>90 with 7700 plug-in module >450 with 7703 plug-in module >900 with 7710 plug-in module
Scanning 4-wire Ω and 3- or 4-wire RTD	>80 with 7700 plug-in module >300 with 7703 plug-in module >400 with 7710 plug-in module
Scanning ACV ⁴⁵	>60 with 7700 plug-in module >170 with 7703 plug-in module >220 with 7710 plug-in module
Scanning Alternating DCV and 2-wire Ω	>90 with 7700 plug-in module >430 with 7703 plug-in module >430 with 7710 plug-in module

DIGITAL I/O READ/WRITE, TOTALIZER READ SPEED

Read Digital Input	7707 plug-in module > 200
Write Digital Output	7706 plug-in module > 1400 7707 plug-in module > 500
Read Totalizer	7706 plug-in module > 100

Notes

41. Reading speeds for autozero off, fixed range, autodelay off, offset compensation off, and open lead detector off where applicable.

42. Buffer measurements: For <0.1 PLC, multisample, and single buffer transfer binary reading only.

43. Computer measurements: For 5 PLC, 1 PLC, and 0.1 PLC single reading and single transfer to computer (USB).

44. Set-up conditions of the factory default setting with the following exceptions: 3.5 digits (0.0005 PLC), autorange off, autozero off, autodelay off, and open lead detection off.

45. Assume the signal is 10 kHz or above.

Typical Function and Range Change Speed

Function	Function Change Time ⁴⁶	Range Change Time ⁴⁷	Autorange Time ⁴⁸
DCV, DCI, or 2-wire Ω ⁴⁸	<4 ms	<1.3 ms	<3.2 ms
4-wire Ω ⁴⁹ or 3-wire RTD			<5.5 ms
Thermistor			–
Frequency or Period (2 ms aperture)	<1800 ms	<50 ms ⁵⁰	<50 ms ⁵⁰
ACV (300 Hz bandwidth)			
ACI (300 Hz bandwidth)	<100 ms	<4 ms	<5 ms
Capacitance	<4 ms	<3 ms	<30 ms
Digitize	<4 ms	<5 ms	–
Diode	<11 ms	–	–
Continuity	<11 ms	–	–
Thermocouple	<4 ms	–	–

Bus Transfer Speed⁵¹ Readings/s

	USB	LAN	GPIB	RS232 (Baud 115200)
Average for 1000 readings (binary)	441,000	268,000	201,000	10,000
Average for 1000 readings with relative timestamp (binary)	272,000	150,000	105,000	2,900
Average for 1000 readings with formatted elements ⁵²	46,000	29,000	17,000	290

Typical Digitize Voltage or Current⁵³

Sampling Rate	Measurements over USB to Computer (readings per second)
10 kS/s	Up to 10,000
50 kS/s	Up to 50,000
100 kS/s	Up to 100,000
1 MS/s up to 7 s maximum duration	At least 90,000

Triggering

Trigger Sources	Front panel trigger key, timer, command interface, LAN/LXI, Trigger In (BNC rear panel), Digital I/O (optional accessory card), and TSP-Link [®] (optional accessory card)
External Trigger Delay	<1 μ s when triggering from accessory card or rear BNC input
External Trigger Jitter	<1 μ s when triggering from accessory card or rear BNC input
External Trigger In/Trigger Out	0 V to 5 V logic signal input and output, TTL-compatible, programmable edge pulse Minimum pulse width: 1 μ s
External Trigger Out, Maximum Rate	Up to 90 kHz, measurement dependent
External Trigger In, Maximum Rate	Up to 150 kHz, measurement dependent

Notes

46. 3.5 digits, autozero off, 0.0005 PLC, excludes measurement time.

47. DCV = 10 V; 2-wire or 4-wire = 1 k Ω ; DCI = 1 mA; ACI = 1 mA; ACV = 1 V; Capacitance = 10 μ F.

48. 2-wire function for 100 Ω range and up. For the 10 Ω range, add 2.7 ms.

49. 4-wire function for 100 Ω range and up. For the 1 Ω and 10 Ω ranges, add 2.7 ms.

50. When ranging to 10 V and above, add 1.8 s.

51. SCPI programmed using 4-byte binary format.

52. Format elements: Reading, relative timestamp, channel, and unit.

53. SCPI programmed using 4-byte binary format.

Scanning

Scan Count	1 to continuous
Scan Interval	0 s to 27.7 hours
Channel Delay	0 to 60 s
Measure Interval	0 s to 27.7 hours

Internal Memory

Maximum Reading Memory (volatile)

Up to 7 million readings with standard buffer (includes channel and formatting information).

Internal (non-volatile) Memory for Saved Scripts and Scan Configurations

6 MB, enables hundreds of scan configurations or TSP scripts to be saved in non-volatile memory.

General Specifications

Line Power

Power Supply	100 V, 120 V, 220 V, and 240 V ($\pm 10\%$)
Power Line Frequency	50 Hz to 60 Hz and 400 Hz, automatically sensed at power-up
Maximum Power Consumption	65 VA
Typical Power Consumption	30 VA
Mains Input Fuse	250 V, 1.25 A slow-blow fuse: Keithley replacement part number FU-106-1.25

Environment and Regulatory

Operating Environment	Specified for 0° to 50°C, $\leq 80\%$ relative humidity at 35°C, altitude up to 2000 meters
Storage Environment	-40° to 70°C
Vibration	MIL-PRF-28800F Class 3, random
Warm-up	30 minutes to rated accuracy
Safety	NRTL listed to UL61010-1 and CSA C22.2 No 61010-1; conforms with European Union Low Voltage Directive
EMC	Conforms to European Union EMC Directive

Mechanical

Display	12.7 cm (5 in.) capacitive touch, color TFT WVGA (800 × 480) with LED backlight
Rack Dimensions (W × H × D)	213.8 mm (8.42 in.) × 88.4 mm (3.48 in.) × 356.6 mm (14.04 in.)
Bench Dimensions (W × H × D)	224.0 mm (8.82 in.) × 107.2 mm (4.22 in.) × 387.4 mm (15.25 in.)
Shipping Weight	4.54 kg (10.0 lb.) instrument only
Input Signal Connections	Front plug-in modules
Plug-in Module Slot	Two slots on the rear panel; see Plug-In Module Accessories
Communication Slot	One slot on rear panel, see Optional Interfaces and Programmable Digital I/O
Cooling	Forced air, fixed speed

Remote Interface: Standard

LAN/LXI version 1.5 core 2016	RJ-45 Connector: 10/100BT. IP Configuration: Static or DHCP (manual or automatic). Web Interface: Virtual front panel. LXI Compliance: LXI version 1.4 core 2016.
USB Device (rear panel, Type B)	2.0 full speed, USBTMC compliant
USB Host (front panel, Type A)	USB 2.0, support for flash drives, FAT32. Capability: Import/export instrument configuration files, reading buffers, screen captures, and scripts

Language

SCPI (default)	Default command set, Standard Commands for Programmable Instruments, SCPI-1999
TSP	Embedded Test Script Processor (TSP) accessible from any host interface; responds to high-speed test scripts comprised of remote commands and statements (for example, branching, looping, and math); able to execute test scripts stored in memory without host intervention
Emulation Modes	Keithley 2700 and 2701

Math Functions

REL, Minimum, Maximum, Average, Standard Deviation, peak-peak, dB, Limit Test, Percent, 1/x, and mX+b with user-defined units displayed

Miscellaneous

Real-time Clock	Lithium battery backup, CR2032 coin-type, factory replaceable, (3+ years of battery life); set and read year, month, day, hour, minute, and second. (Note: Seconds are not adjustable.)
Timestamp Resolution	15 ns with standard or full buffer style
Password Protection	30 characters
Alarms	Up to six: see Optional Interfaces and Programmable Digital I/O
Power Failure Recovery Mode	User selectable, resumes scanning once power is re-applied

Optional Interfaces and Programmable Digital I/O

KTTI-GPIB	GPIB IEEE-488.1 compliant; supports IEEE-488.2 common commands and status model topology
KTTI-RS232	RS232, 9-pin d-sub female connector; standard baud rates from 300 to 115,200 bps are supported
KTTI-TSP	RJ-45 (quantity 2); TSP-Link® expansion interface allows TSP-enabled instruments to trigger and communicate with each other (Requires Category 5e 10/100 BT Ethernet crossover cabling)
Digital I/O	For KTTI-RS232, KTTI-GPIB, and KTTI-TSP Connector: 9 pin d-sub female 5 V Power Supply Pin: Limited to 500 mA > 4 V (solid-state fuse protected) Lines: Six input / output, user-defined for control, alarms (limits), or triggering Input Signal Levels: 0.7 V (maximum logic low), 3.7 V (minimum logic high) Input Voltage Limits: -0.25 V (absolute minimum), 5.25 V (absolute maximum) Maximum Source Current: 2.0 mA at > 2.7 V (per pin) Maximum Sink Current: -50 mA at 0.7 V (per pin, solid state fused)

Ordering Information

DAQ6510	Data Acquisition/Multimeter System with 2 Module Slots
DAQ6510/7700	Data Acquisition/Multimeter System with Model 7700 20-Channel Differential Multiplexer Module

Supplied Accessories

1757	Pair, general purpose test lead set, 1000 V Cat II
USB-B-1	USB Cable, Type A to Type B, 1 m (3.3 ft)
	Traceable Calibration Certificate
	Three-Year Warranty

Instruction Manuals/Documentation (available at www.tek.com/DAQ6510)

DAQ6510 Quick Start Guide

DAQ6510 User's Manual

DAQ6510 Reference Manual

Software and Drivers (available at tek.com)

IVI/VISA Drivers for Microsoft® Visual Basic®, Visual C/C++®

National Instruments (NI®) LabView™, NMI LabWindows™/CVI (available at ni.com)

TSP Toolkit Software available at www.tek.com

KickStart available at www.tek.com/kickstart

Optional Series 7700 Plug-in Switch Modules

7700	20-channel Differential Multiplexer Module with Automatic CJC
7701	32-channel Differential Multiplexer Module
7702	40-channel Differential Multiplexer Module
7703	32-channel, High-Speed, Differential Multiplexer Module
7705	40-channel Single-Pole Control Module
7706	All-in-one I/O Module
7707	32-channel Digital I/O Module
7708	40-channel Differential Multiplexer Module with Automatic CJC
7709	2-pole, 6×8 Matrix Module
7710	20-channel Solid State Differential Multiplexer with Automatic CJC

Optional Interfaces and Programmable Digital I/O

KTTI-RS232	RS-232 Communication and Digital I/O Accessory, user-installable
KTTI-GPIB	GPIB Communication and Digital I/O Accessory, user-installable
KTTI-TSP	TSP-Link Communication and Digital I/O Accessory, user-installable (Requires Category 5e 10/100 BT Ethernet crossover cabling)

Available Accessories

Test Leads and Probes

1752	Premium Safety Test Lead Kit
1754	2-Wire Universal 10-Piece Test Lead Kit
5804	Kelvin (4-Wire) Universal 10-Piece Test Lead Kit

PC Communication Interface and Cables

KPCI-488LPA	IEEE-488 Interface for PCI Bus
KUSB-488B	IEEE-488 USB-to-GPIB Interface Adapter
174694600	CAT5E Crossover Cable for TSP-Link/Ethernet

Triggering and Control

8503	DIN to BNC Trigger Cable
-------------	--------------------------

Rack Mount Kits

4299-8	Single Fixed Rack Mount Kit
4299-9	Dual Fixed Rack Mount Kit

Replacement Fuses

FU-99-1	Current Input Fuse, 3 A, 250 V Fast Acting 5×20 mm
FU-106-1.25	Main Input Fuse, 1.25 A, 250 V, Slo-Blo

Available Services

Extended Warranties

Instruments

DA06510-EW	3 year factory warranty extended to 4 years from date of shipment
DA06510-5Y-EW	3 year factory warranty extended to 5 years from date of shipment
Plug-in Modules	See Plug-In Module Data Sheets

Calibration Contracts

Instruments

C/DA06510-3Y-DATA	KeithleyCare 3 Year Calibration w/Data Plan
C/DA06510-5Y-DATA	KeithleyCare 5 Year Calibration w/Data Plan
C/DA06510-3Y-STD	KeithleyCare 3 Year Standard Calibration Plan
C/DA06510-5Y-STD	KeithleyCare 5 Year Standard Calibration Plan

7700 20-channel, Differential Multiplexer Module with Automatic CJC, Screw Terminals, and up to 50MHz Bandwidth

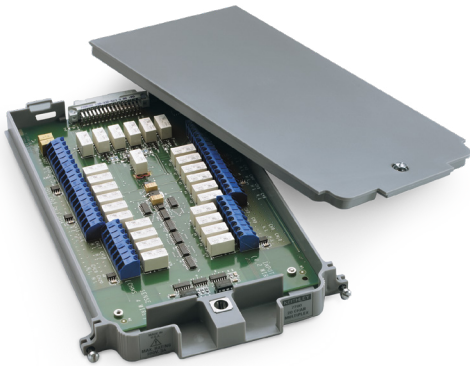

The 7700 plug-in module offers 20 channels of 2-pole or 10 channels of 4-pole multiplexer switching that can be configured as two independent banks of multiplexers. There are two additional protected channels for current measurements. Automatic CJC is provided so that no other accessories are required to make thermocouple temperature measurements. In addition, the 7700 contains latching electromechanical relays that enable signal bandwidths of up to 50 MHz. The 7700 is ideal for RTD, thermistor, and thermocouple temperature applications.

Key Features

- 20 channels for general purpose measurements, plus two channels to measure current
- Oversize screw terminal connection blocks are standard for easier connections
- 50 MHz bandwidth
- 300 V, 1 A capacity for voltage channels; 60 W, 125 VA
- 3 A capacity for current channels
- Low insertion loss of up to 50 MHz
- Relay closures stored in onboard memory

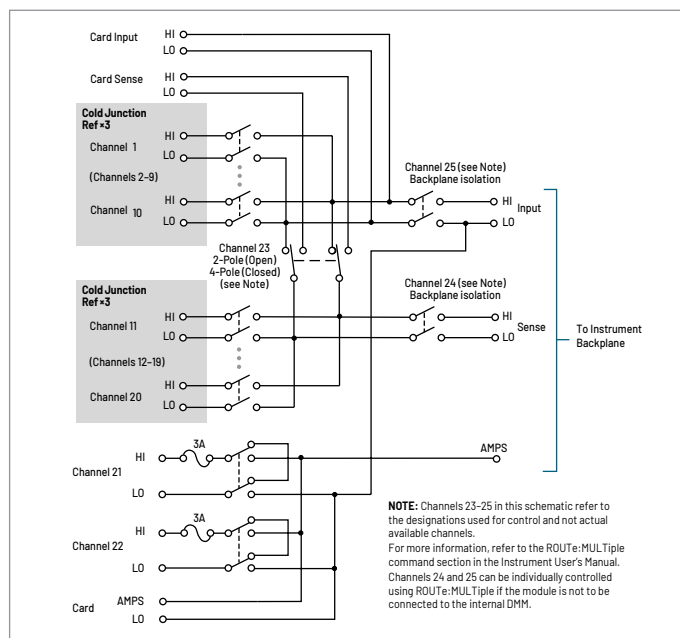

Specifications

Capabilities

Channels 1-20	Multiplex one of twenty 2-pole or one of ten 4-pole signals into DMM.
Channels 21-22	Multiplex one of two 2-pole current signals into DMM.

Inputs

Maximum Signal Level	
Channels (1-20)	300 V DC or 300 V rms (425 V peak) for AC waveforms, 1 A switched, 60 W, 125 VA maximum.
Channels (21-22)	60 V DC or 30 V rms, 3 A switched, 60 W, 125 VA maximum.
Contact Life (typ.)	>10 ⁹ operations at max. signal level. >10 ⁸ operations no load ¹ .

1. Open thermocouple detector on during thermocouple measurements. Minimum signal level 10 mV, 10 μA.

Contact Resistance	<1 Ω at end of contact life.
Contact Potential	<±500 nV typical per contact, 1 μV max. <±500 nV typical per contact pair, 1 μV max.
Offset Current	<100 pA.
Connector Type	Screw terminal, #20 AWG wire size.
Isolation Between Any Two Terminals:	>10 ¹⁰ Ω, <100 pF.
Isolation Between Any Terminal and Earth:	>10 ⁹ Ω, <200 pF.

	w/Internal DMM	w/o Internal DMM
<0.1 dB	1 MHz	1 MHz
<3 dB	2 MHz	50 MHz

Crosstalk (50 Ω Load):

	w/Internal DMM	w/o Internal DMM
10 MHz	<-40 dB	<-40 dB
25 MHz	—	<-25 dB

Common Mode Voltage

300 V or 300 V rms (425 V peak) for AC waveforms between any terminal and chassis.

General

20 Channels	20 channels of 2-pole relay input. All channels configurable to 4-pole.
2 Channels	2 channels of current only input.
Relay Type	Latching electromechanical.
Actuation Time	<3 ms.

Environmental and Safety

Operating Environment: Specified for 0° to 50°C. Specified to 80% R.H. at 35°C.
Storage Environment: -25° to 65°C.
EMC: Conforms to European Union EMC Directive.
Safety: Conforms to European Union Low Voltage Directive
RoHS: Conforms to European Union RoHS Directive

Weight	0.45 kg (1 lb).
---------------	-----------------

Supplied Accessories

CC-92-1	Set of 20 Cable Ties
TL-23	Screwdriver

Available Services

7700-3Y-EW	1-year factory warranty extended to 3 years from date of shipment
-------------------	---

Ordering Information

7700	20-channel, Differential Multiplexer Module with Automatic CJC and Screw Terminals
Warranty	1 year

7701 32-channel Differential Multiplexer Module



The 7701 plug-in module offers 32 channels of 2-pole or 16 channels of 4-pole multiplexer switching. Its 32 channels can be configured for common-side 4-wire ohms. They can also be configured as two independent banks of multiplexers. It is ideal for RTD or thermistor temperature applications.

Key Features

- Configurable for 32 channels of differential measurements, with up to 16 channels of 4-pole measurements
- Two female D-shell connectors are standard for secure hook-up and quick teardown
- 150 V, 1 A capacity for voltage channels; 60 W, 125 VA
- Relay closures stored in onboard memory
- Screw terminal jumpers allow user-configurable DMM connections

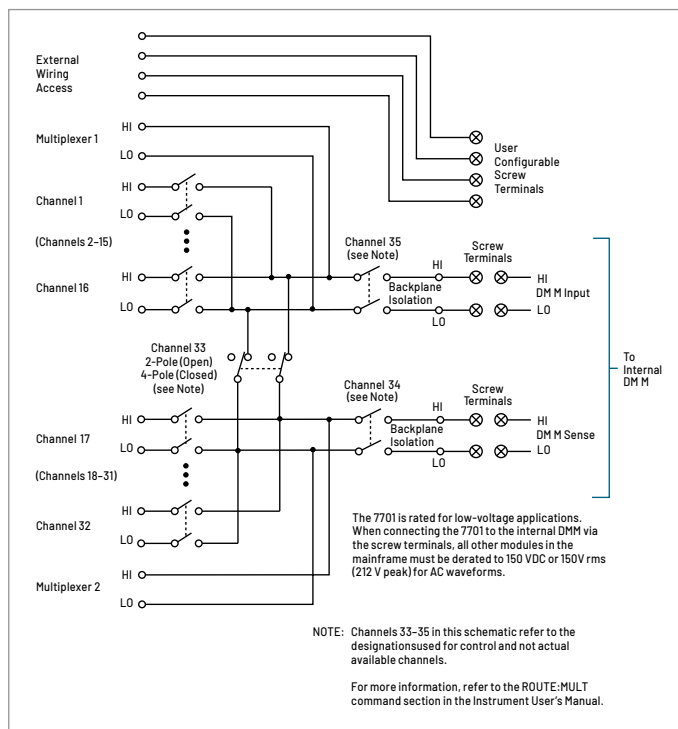

Specifications

Capabilities	
Channels 1-32	Multiplex one of 32 2-pole or one of 16 4-pole signals into DMM. Configuration supports dual 1x16 independent multiplexers.
Inputs	
Maximum Signal Level	Any channel to Any Channel (1-32): 150 V DC or 150 Vrms (212 V peak) for AC waveforms, 1 A switched, 60 W, 125 VA maximum.
Contact Life (typ):	>10 ⁶ operations at max. signal level. >10 ⁸ operations no load ¹ .
¹ . Minimum signal level 10 mV, 10 μA.	
Contact Resistance	<1 Ω any path and additional 1 Ω at end of contact life.
Contact Potential	<6 μV per contact pair.
Offset Current	<100 pA.
Connector Type	50-pin female D-shell, Channels 1-24. 25-pin female D-shell, Channels 25-32. Supplied with male IDC ribbon cable connectors.
Isolation Between Any Two Terminals	>10 ⁹ Ω, <200 pF.
Isolation Between Any Terminal and Earth	>10 ⁹ Ω, <400 pF.
Cross Talk (1 MHz, 50 Ω Load)	<-35 dB.
Insertion Loss (50 Ω Source, 50 Ω Load)	<0.35 dB below 1 MHz. <3 dB below 2 MHz.
Common Mode Voltage	300 VDC or 300 Vrms (425 V peak) for AC waveforms between any terminal and chassis.
General	
32 Channels	32 channels of 2-pole relay input. All channels configurable to 4-pole.
Relay Type	Latching electromechanical.
Actuation Time	<3 ms.
DMM Connections	Screw terminals provide internal DMM connections to channels 34 and 35 and connections to external wiring access.

Environmental and Safety	
Operating Environment:	Specified for 0° to 50°C. Specified to 80% R.H. at 35°C.
Storage Environment:	-25° to 65°C.
EMC:	Conforms to European Union EMC Directive.
Safety:	Conforms to European Union Low Voltage Directive
RoHS:	Conforms to European Union RoHS Directive
Weight	<0.52 kg (1.16 lb).

Supplied Accessories	
7709-306A	50-pin D-Sub Male IDC Connector Kit
7709-307A	25-pin D-Sub Male IDC Connector Kit
J-15	Jumper Wires, quantity 4

Available Accessories	
7789	50-pin male, 25-pin male D-shell solder cup connectors
7790	50-pin male, 50-pin female, 25-pin male D-shell IDC connectors

Available Services	
7701-3Y-EW	1-year factory warranty extended to 3 years from date of shipment

Ordering Information	
7701	32-channel, Differential Multiplexer Module
Warranty	1 year

7702 40-channel, Differential Multiplexer Module with Screw Terminals

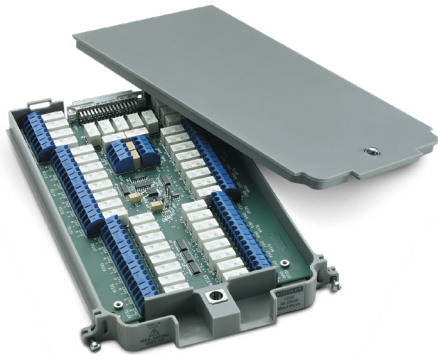

The 7702 plug-in module offers 40 channels of 2-pole or 20 channels of 4-pole multiplexer switching that can be configured as two independent banks of multiplexers. The 7702 provides two additional protected channels for current measurements. It is ideal for RTD, thermistor, and thermocouple temperature applications.

Key Features

- 40 channels for general purpose measurements, plus 2 channels to measure current
- Two- or four-wire measurement
- Oversize screw terminal connection blocks are standard for easier connection
- 300 V, 1 A capacity for voltage channels; 60 W, 125 VA
- 3 A capacity for current channels
- Relay closures stored in onboard memory

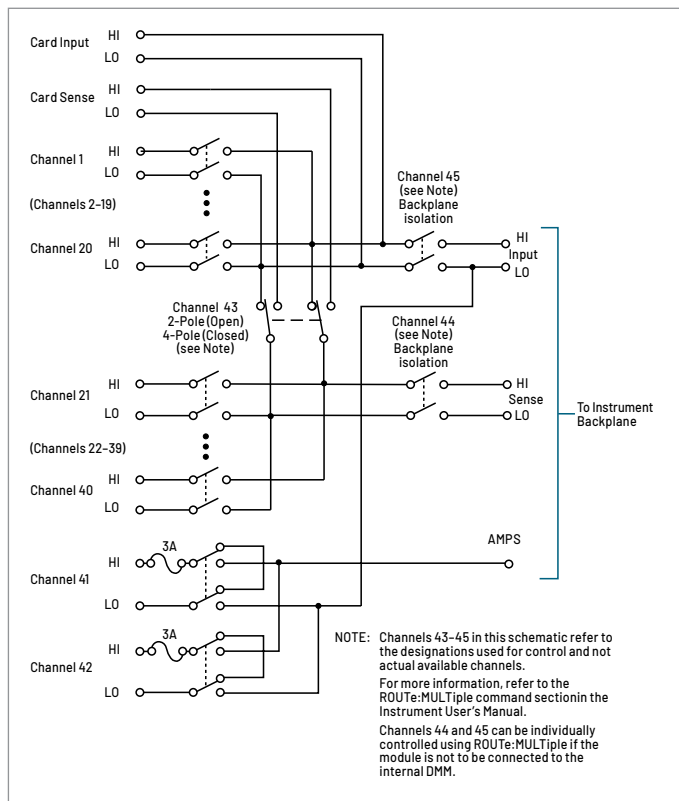

Specifications

Capabilities

Channels 1-40 Multiplex one of 40 2-pole or one of 20 4-pole signals into DMM.

Channels 41-42 Multiplex one of 2 2-pole current signals into DMM.

Inputs

Maximum Signal Level

Channels (1-40) 300 V DC or rms, 1 A switched, 60 W, 125 VA maximum.

Channels (41-42) 60 V DC or 30 V rms, 3 A switched, 60 W, 125 VA maximum.

Contact Life (typ.) >10⁵ operations at max. signal level.

>10⁸ operations no load¹.
1. Minimum signal level 10 mV, 10 μA.

Contact Resistance <1 Ω at end of contact life.

Contact Potential <±500 nV typical per contact, 1 μV max.
<±500 nV typical per contact pair, 1 μV max.

Offset Current <100 pA.

Connector Type Screw terminal, #20 AWG wire size.

Isolation Between Any Two Terminals

>10¹⁰ Ω, <100 pF.

Isolation Between Any Terminal and Earth

>10⁹ Ω, <200 pF.

Cross Talk (10 MHz, 50 Ω Load)

<-40 dB.

Insertion Loss (50 Ω Source, 50 Ω Load)

<0.1 dB below 1 MHz. <3 dB below 2 MHz.

Common Mode Voltage

300V between any terminal and chassis.

General

40 Channels 40 channels of 2-pole relay input. All channels configurable to 4-pole.

2 Channels 2 channels of current only input.

Relay Type Latching electromechanical.

Actuation Time <3 ms.

Environmental and Safety

Operating Environment: Specified for 0° to 50°C. Specified to 80% R.H. at 35°C.

Storage Environment: -25° to 65°C.

EMC: Conforms to European Union EMC Directive.

Safety: Conforms to European Union Low Voltage Directive

RoHS: Conforms to European Union RoHS Directive

Weight 0.5 kg (1.1 lb).

Supplied Accessories

CC-92-1 Set of 20 Cable Ties

TL-23 Screwdriver

Available Services

7702-3Y-EW 1-year factory warranty extended to 3 years from date of shipment

Ordering Information

7702 40-channel Differential Multiplexer Module with Screw Terminals

Warranty 1 year

7703 32-channel, High Speed, Differential Multiplexer Module



The 7703 plug-in module offers 32 channels of 2-pole or 16 channels of 4-pole multiplexer switching that can be configured as two independent banks of multiplexers. The non-latching reed relays provide high speeds and are designed for 300 volt, 500 mA; 10 VA. The relay closures are stored in onboard memory. The 7703 is ideal for RTD and thermistor temperature applications.

Key Features

- 32 channels for general purpose measurements
- Relay actuation time of less than 1ms for high-speed scanning
- Two- or four-wire measurement
- Two 50-pin female D-sub connectors are standard for secure hook-up and quick teardown

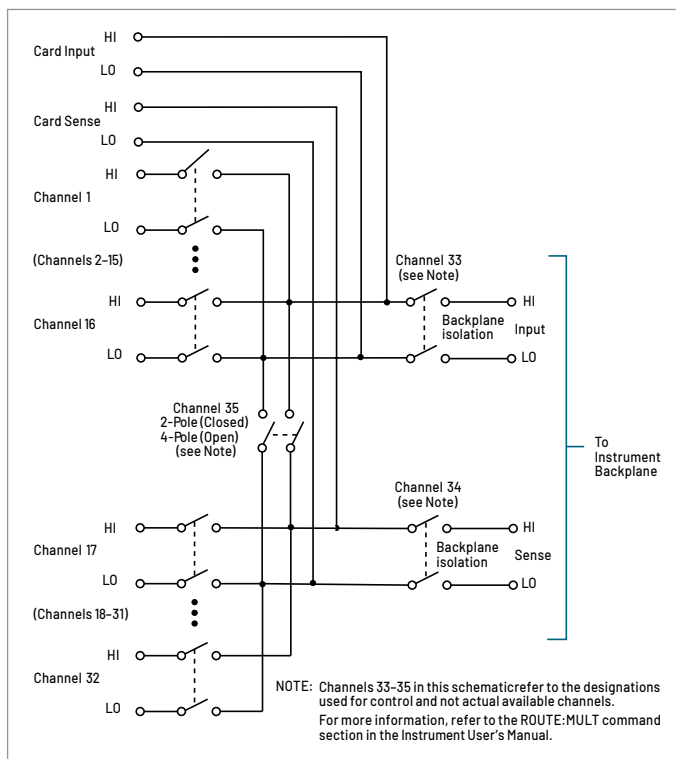

Specifications

Capabilities

Channels 1-32 Multiplex one of 32 2-pole or one of 16 4-pole signals into DMM.

Inputs

Maximum Signal Level

Channels (1-32) 300 V DC or rms, 0.5 A switched, 10 W maximum.

Contact Life (typ.) >5×10⁴ operations at max. signal level.
>10⁸ operations cold switching.

Contact Resistance <1 Ω at end of contact life.

Contact Potential <±3 μV typical per contact, 6 μV max.
<±3 μV typical per contact pair, 6 μV max.

Offset Current <100 pA.

Connector Type 50 pin D-sub ×2.

Relay Drive Current 20 mA per channel.

Isolation Between Any Two Terminals

>10⁹ Ω, <200 pF.

Isolation Between Any Terminal and Earth

>10⁹ Ω, <400 pF.

Cross Talk (1 MHz, 50 Ω Load)

<-40 dB.

Insertion Loss (50 Ω Source, 50 Ω Load)

<0.35 dB below 1 MHz. <3 dB below 2 MHz.

Common Mode Voltage

300 V between any terminal and chassis.

General

32 Channels 32 channels of 2-pole relay input. All channels configurable to 4-pole.

Relay Type Reed.

Actuation Time <1 ms.

Environmental and Safety

Operating Environment: Specified for 0° to 50°C. Specified to 40% R.H. at 35°C.

Storage Environment: -25° to 65°C.

EMC: Conforms to European Union EMC Directive.

Safety: Conforms to European Union Low Voltage Directive

RoHS: Conforms to European Union RoHS Directive

Weight 0.8 kg (1.75 lbs).

Supplied Accessories

7703-306A 50-pin D-Sub Male Shell Connector Kit, quantity 2

Available Accessories

7705-MTC-2 50 Pin Male to Female D-sub Cable, 2 m (6.6 ft).

7788 50-pin D-Sub male connector kit, quantity 2

7790 50-pin male, 50-pin female, 25-pin male D-shell IDC connectors

Available Services

7703-3Y-EW 1-year factory warranty extended to 3 years from date of shipment

Ordering Information

7703 32-channel, High Speed, Differential Multiplexer Module

Warranty 1 year

7705 40-channel, Single-pole Control Module



The 7705 plug-in module offers 40 channels of independent switching. These channels are designed to control power to the DUT and switching loads. They can also directly control light indicators, relays, etc.

Key Features

- 300 V, 2 A capacity
- Two 50-pin female D-sub connectors are standard for secure hook-up and quick teardown
- Relay closures stored in onboard memory

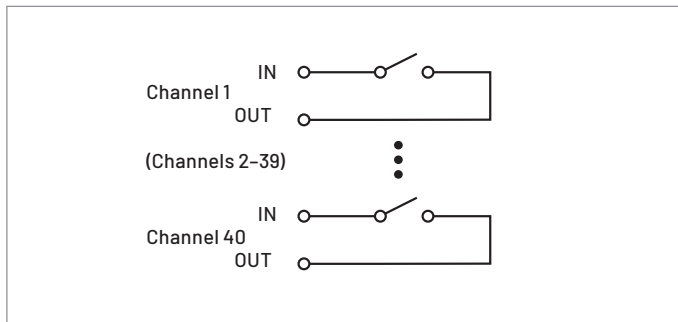

Specifications

Inputs

Maximum Signal Level	300 VDC or rms, 2 A switched, 60 W (DC, resistive), 125 VA (AC, resistive).
Contact Life	No Load: 10 ⁶ closures. At Maximum Signal Levels: 10 ⁵ closures. 1. Minimum signal level 10 mV, 10 μA.
Channel Resistance (per conductor)	<1 Ω.
Contact Potential	≤4 μV per contact.
Offset Current	<100 pA.
Actuation Time	3 ms.
Isolation	Channel to Channel: >10 ⁹ Ω, <50 pF. Common Mode: >10 ⁹ Ω, <100 pF.
Crosstalk (1 MHz, 50 Ω load)	<-35 dB.
Insertion Loss (50 Ω source, 50 Ω load)	<0.3 dB below 1 MHz, <3 dB below 10 MHz.
Common Mode Voltage	300 V between any terminal and chassis.

General

Relay Switch Configuration	40 independent channels of 1-pole switching. Isolated from internal DMM.
Contact Configuration	1 pole Form A.
Relay Type	Latching electromechanical.
Connector Type	Two 50-pin female D-sub connectors.
Environmental and Safety	Operating Environment: Specified for 0° to 50°C. Specified to 80% R.H. at 35°C. Storage Environment: -25° to 65°C. EMC: Conforms to European Union EMC Directive. Safety: Conforms to European Union Low Voltage Directive RoHS: Conforms to European Union RoHS Directive
Weight	0.45 kg (1 lb).

Supplied Accessories

7703-306A	50-pin D-Sub Male Shell Connector Kit, quantity 2
------------------	---

Available Accessories

7705-MTC-2	50 Pin Male to Female D-sub Cable, 2 m (6.6 ft).
7788	50-pin D-Sub male connector kit, quantity 2
7790	50-pin male, 50-pin female, 25-pin male D-shell IDC connectors

Available Services

7705-3Y-EW	1-year factory warranty extended to 3 years from date of shipment
-------------------	---

Ordering Information

7705	40-channel, Single-pole Control Module
Warranty	1 year

7706 All-in-One I/O Module

20-channel Differential Multiplexer with Automatic CJC, 16 Digital Outputs, 2 Analog Outputs, a Counter/Totalizer, and Screw Terminals

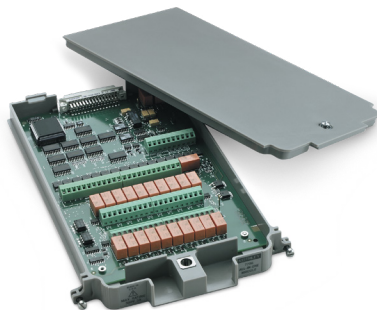

The 7706 plug-in module offers 20 channels of 2-pole or 10 channels of 4-pole multiplexer switching with automatic CJC, as well as two analog output channels, 16 digital outputs, and one event counter/totalizer. The event counter/totalizer can be used to monitor and control system components, such as fixtures, limit switches, pass/fail indicators, external voltage sources, loads, door closures, revolutions, etc., while performing mixed signal measurements. The 7706 is ideal for RTD, thermistor, and thermocouple temperature applications.

Key Features

- 20 channels of analog input (w/automatic CJC) for general-purpose measurements
- 16 channels of digital output
- 2 analog outputs (± 12 V, 5 mA)
- 300 V, 1 A capacity; 60 W, 125 VA maximum
- Configurable as two independent banks of multiplexers
- Relay closures stored in onboard memory

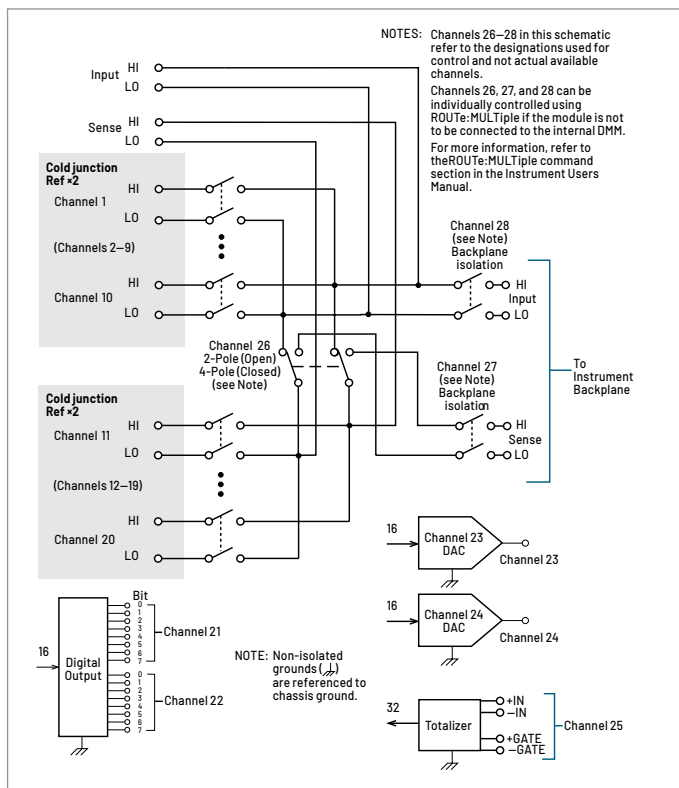

Specifications

Capabilities	
Channels 1–20	Multiplex one of 20 2-pole or one of 10 4-pole signals into DMM.
Channels 21–22	16 Digital Outputs.
Channels 23–24	Analog Voltage Output (2).
Channels 25	Totalize Input.
	Channels 21–25 are referenced to chassis ground.

Inputs (Channels 1–20)	
Maximum Signal Level (Channels 1–20)	300 V DC or rms, 1 A switched, 60 W, 125 VA maximum.
Safety Category	CAT 1
Contact Life (typ.)	>10 ⁵ operations at max. signal level; >10 ⁸ operations no load! 1. Minimum signal level 10 mV, 10 μ A.
Contact Resistance	<1 Ω at end of contact life.
Contact Potential	< ± 2 μ V typical per contact, 3 μ V max.
Offset Current	<100 pA.
Connector Type	Screw terminal, #22 AWG wire size.
Isolation Between Any Two Terminals	>10 ⁹ Ω , <100 pF.
Isolation Between Any Terminal and Earth	>10 ⁹ Ω , <200 pF.
Cross Talk (10MHz, 50 Ω Load)	<-35 dB.
Insertion Loss (50 Ω Source, 50 Ω Load)	<0.1 dB below 1 MHz. <3 dB below 2 MHz.
Common Mode Voltage: 300 V between any terminal and chassis.	

Digital Output (Channels 21 and 22)	
V_{out(L)}	<0.8 V @ I _{out} = 400 mA.
V_{out(H)}	>2.4 V @ I _{out} = 1 mA.
V_{out(H)Max.}	<42 V with external open drain pull-up.
Write Speed	50/s.
Analog Voltage Output (Channels 23 and 24)	
DAC 1, 2	± 12 V @ 1 mA max, non-isolated, ± 10 V @ 5 mA max.
Resolution	1 mV.
I_{out}	5 mA max.
Settling Time	1 ms to 0.01% of output.
Accuracy \pm(% of output + mV)	1 year $\pm 5^\circ\text{C}$: 0.15% + 19 mV; 90 day $\pm 5^\circ\text{C}$: 0.1% + 19 mV; 24 hour $\pm 1^\circ\text{C}$: 0.04% + 19 mV.

Temperature Coefficient:	$\pm(0.015\% + 1 \text{ mV})/^\circ\text{C}$.
Write Speed	50/s.
Totalize Input (Channel 25)	
Maximum Count	232–1.
Totalize Input	100 kHz (max), rising or falling edge, programmable.
Signal Level	1 Vp-p (min), 42 Vpk (max).
Threshold	0 V or TTL, jumper selectable.
Gate Input	TTL-Hi, TTL-Lo, or none.
Count Reset	Manual or Read+Reset.
Read Speed	50/s.

General	
20 Channels	20 channels of 2-pole relay input. All channels configurable to 4-pole.
Relay Type	Latching electromechanical.
Actuation Time	<3 ms.
Environmental and Safety	
	Operating Environment: Specified for 0° to 50°C. Specified to 80% R.H. at 35°C.
	Storage Environment: -25° to 65°C.
	EMC: Conforms to European Union EMC Directive.
	Safety: Conforms to European Union Low Voltage Directive
	RoHS: Conforms to European Union RoHS Directive

Weight	0.5 kg (1.1 lbs).
Supplied Accessories	
CC-92-1	Set of 20 Cable Ties
TL-23	Screwdriver

Available Services	
7706-3Y-EW	1-year factory warranty extended to 3 years from date of shipment

Ordering Information	
7706	All-in-One I/O Module
Warranty	1 year

7707 32-channel Digital I/O Module with 10-channel Differential Multiplexer



The 7707 plug-in module offers 10 channels of 2-pole or 5 channels of 4-pole multiplexer switching that can be configured as two independent banks of multiplexers. The 7707 also provides 32 digital input/output channels (four 8-bit ports) for I/O control. Connect the 7707 to industry standard solid-state relays to switch up to 980 VA.

Key Features

- 300 V, 1 A capacity; 60 W, 125 VA maximum (analog)
- 33 V, 100 mA capacity (digital)
- Digital outputs are short circuit protected
- Relay closures stored in onboard memory

Ordering Information

7707	32-channel Digital I/O Module with 10-channel Differential Multiplexer
Warranty	1 year

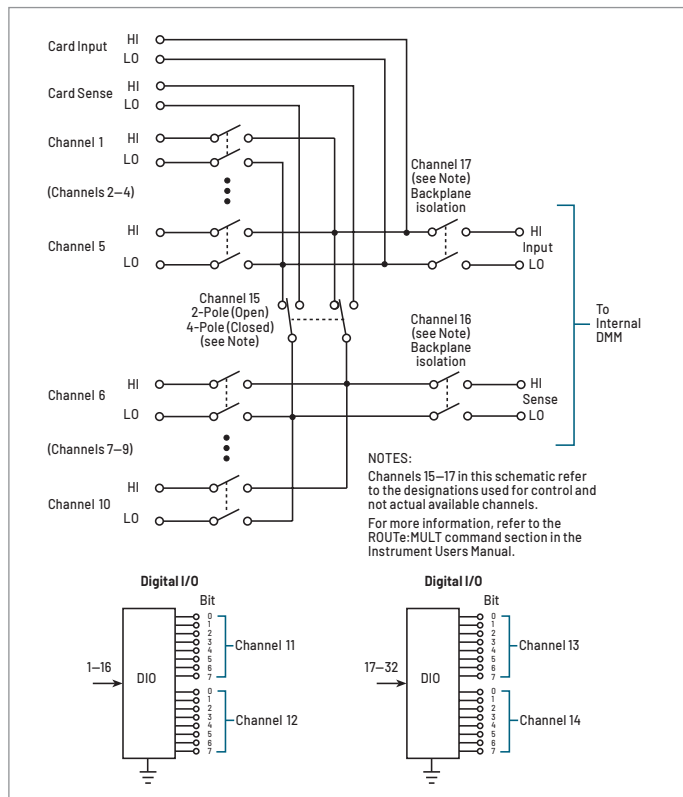

Specifications

Capabilities

Channels 1-10	Multiplex one of 10 2-pole or one of 5 4-pole signals into DMM.
Channels 11-14	32 Digital Inputs/Outputs referenced to chassis ground.
Thermal Protection	Channels 11-14 are thermally protected to 1 A up to 25 V.

Inputs (Channels 1-10)

Maximum Signal Level: Any Channel to Any Channel (1-10): 300 VDC or 300 Vrms (425 V peak) for AC waveforms, 1 A switched, 60 W, 125 VA maximum.

Contact Life (typ.) >10⁶ operations at max. signal level
>10⁸ operations no load¹.

1. Minimum signal level 10 mV, 10 μA.

Contact Resistance <1 Ω any path and additional 1 Ω at end of contact life.

Contact Potential <6 μV typical per contact pair and additional 5 μV with Channels 11-14 at rate V_{out(L)}.

Offset Current <100 pA.

Connector Type: 50-pin male D-shell, Channels 11-14. 25-pin female D-shell, Channels 1-10. Supplied with female and male IDC ribbon cable connectors.

Isolation Between Any Two Terminals

>10⁹ Ω, <100 pF with isolation channels 16 and 17 open.

Isolation Between Any Terminal and Earth: >10⁹ Ω, <200 pF.

Cross Talk (1 MHz, 50 Ω Load): <-35 dB.

Insertion Loss (50 Ω Source, 50 Ω Load)

<0.1 dB below 1 MHz. <3 dB below 2 MHz.

Common Mode Voltage: 300 VDC or 300 Vrms (425 V peak) for AC waveforms between any terminal and chassis.

Digital Input/Output (Channels 11-14)

V_{in(L)}: <0.8 V (TTL). V_{in(H)}: >2 V (TTL).

V_{out(L)}: <1.0 V @ I_{out} = 100 mA. V_{out(H)}: >2.4 V @ I_{out} = 1 mA.

V_{out(H)MAX.}: <40 V with external open drain pull-up.

Read/Write Speed 50/s.

General

10 Channels	10 channels of 2-pole relay input. All channels configurable to 4-pole.
Relay Type	Latching electromechanical.
Actuation Time	<3 ms.
Capacity	2700: (1) 7707 and (1) 77XX, except 7706. 2701: Any combination of 77XX modules. 2750: (4) 7707 and (1) 77XX, except 7706. A 7706 module may be substituted for a 7707 module.

Environmental and Safety

Operating Environment: Specified for 0° to 50°C. Specified to 80% R.H. at 35°C.

Storage Environment: -25° to 65°C.

EMC: Conforms to European Union EMC Directive.

Safety: Conforms to European Union Low Voltage Directive

RoHS: Conforms to European Union RoHS Directive

Weight <0.5 kg (1.16 lb).

Supplied Accessories

7707-306A	50-pin D-Sub Female IDC Connector Kit
7709-307A	25-pin D-Sub Male IDC Connector Kits

Available Accessories

7790	50-pin Male, 50-pin Female, 25-pin Male D-shell IDC Connectors
7705-MTC-2	50 Pin Male to Female D-sub Cable, 2 m (6.6 ft).
7707-MTC-2	25 Pin Male to Female D-sub Cable, 2 m (6.6 ft).

Available Services

7707-3Y-EW	1-year factory warranty extended to 3 years from date of shipment.
-------------------	--

7708 40-channel, Differential Multiplexer Module with Automatic CJC and Screw Terminals

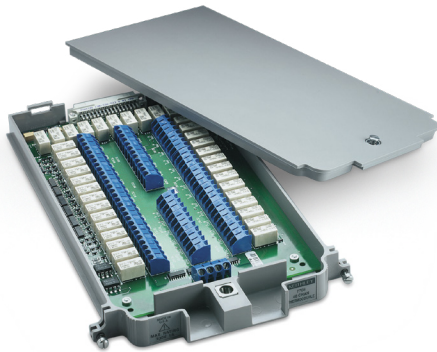

The 7708 plug-in module offers 40 channels of 2-pole or 20 channels of 4-pole multiplexer switching that can be configured as two independent banks of multiplexers. The built-in CJC sensors automatically linearize thermocouples, making the 7708 ideal for RTD, thermistor, and thermocouple temperature applications. It is also well suited for mixed-signal measurement applications that require multi-point monitoring, such as environmental stress screening.

Key Features

- 40 differential channels for general purpose measurements
- Two- or four-wire measurements
- 300 V, 1 A capacity for voltage channels; 60 W, 125 VA
- Oversize screw terminal connection blocks are standard for easier connection
- Relay closures stored in onboard memory

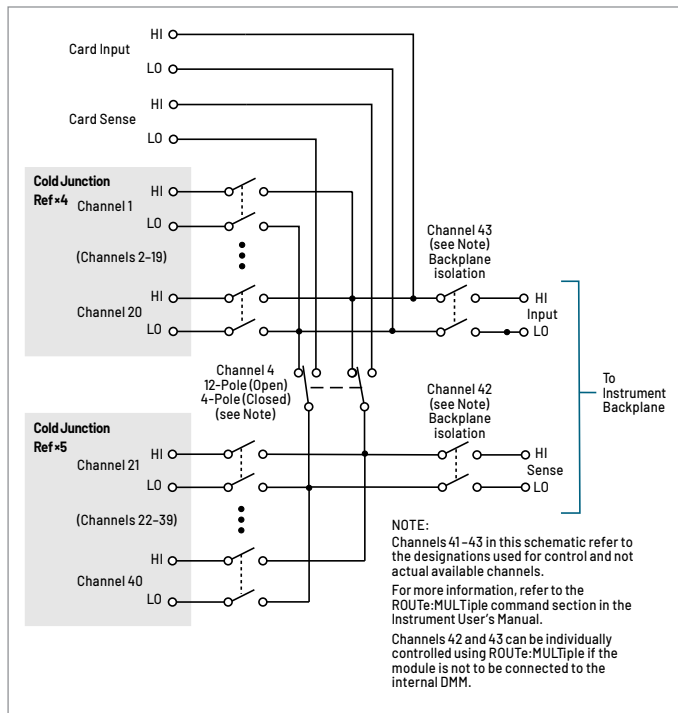

Specifications

Capabilities

Channels 1–40 Multiplex one of 40 2-pole or one of 20 4-pole signals into DMM.

Inputs

Maximum Signal Level

Channels (1–40) 300 V DC or rms, 1 A switched, 60 W, 125 VA maximum.

Contact Life (typ.) >10⁵ operations at max. signal level.
>10⁸ operations no load¹.

1. Open thermocouple detector on during thermocouple measurements. Minimum signal level 10 mV, 10 μA.

Contact Resistance <2 Ω at end of contact life.

Contact Potential <±500 nV typical per contact, 1 μV max.
<±500 nV typical per contact pair, 1 μV max.

Offset Current <100 pA.

Connector Type Screw terminal, #20 AWG wire size.

Isolation Between Any Two Terminals >10⁹ Ω, <200 pF.

Isolation Between Any Terminal and Earth >10⁹ Ω, <400 pF.

Cross Talk (1 MHz, 50 Ω Load) <-40 dB.

Insertion Loss (50 Ω Source, 50 Ω Load) <0.1 dB below 1 MHz. <3 dB below 2 MHz.

Common Mode Voltage 300 V between any terminal and chassis.

General

40 Channels 40 channels of 2-pole relay input. All channels configurable to 4-pole.

Relay Type Latching electromechanical.

Actuation Time <3 ms.

Environmental and Safety

Operating Environment: Specified for 0° to 50°C. Specified to 80% R.H. at 35°C.

Storage Environment: -25° to 65°C.

EMC: Conforms to European Union EMC Directive.

Safety: Conforms to European Union Low Voltage Directive

RoHS: Conforms to European Union RoHS Directive

Weight 0.52 kg (1.16 lb).

Supplied Accessories

CC-92-1 Set of 20 Cable Ties

TL-23 Screwdriver

Available Accessories

7708-3Y-EW 1-year factory warranty extended to 3 years from date of shipment

Ordering Information

7708 40-channel Differential Multiplexer Module with Automatic CJC and Screw Terminals

Warranty 1 year

7709 7709 6×8 Matrix Module



The 7709 plug-in module is a two-pole, 6×8 matrix module. It can connect any combination of six differential channels of instrumentation to any combination of eight differential device-under-test channels. The instrumentation can be AC and DC sources, internal or external meters, oscilloscopes, etc. This matrix configuration allows wide flexibility for complex test systems.

Key Features

- Automatic two- or four-wire connection to DMM
- 6 row × 8 column matrix
- Expandable to larger switch configurations by daisy-chaining or cascading multiple modules
- Two female D-sub connectors are standard for secure hook-up and quick teardown
- 300 V, 1 A capacity
- Relay closures stored in onboard memory

Ordering Information

7709	6×8 Matrix Module
Warranty	1 year

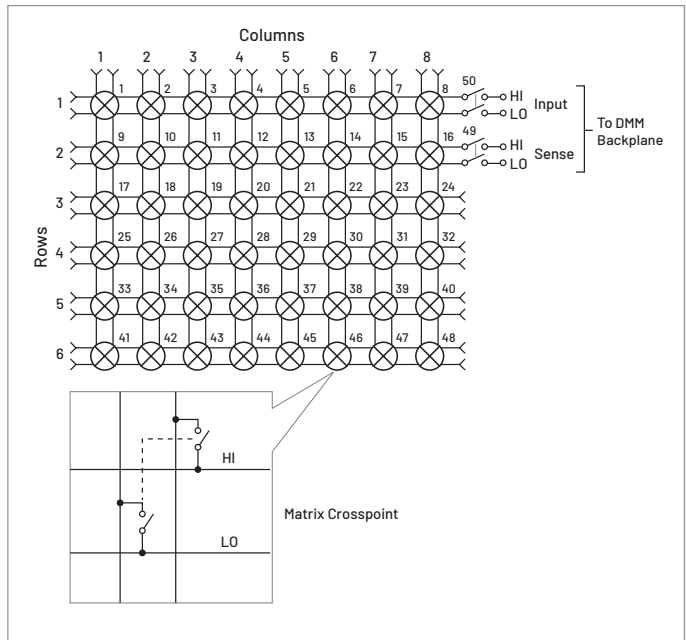

Specifications

Capabilities

DMM Connection	
2-Wire Functions	Row 1, channels 1–8, through channel 50.
4-Wire Functions	Row 1, channels 1–4 (Source to Input) through channel 50 and Row 2, channels 13–16 (Sense), through channel 49.

Close Channel	CLOSE command connects channels 1–8 to DMM. For 4-wire, channels 1–4 are automatically paired with channels 13–16. ROUTe:MULTiple allows any combination of rows and columns to be connected at the same time.
----------------------	--

Inputs

Maximum Signal Level	Any Channel to Any Channel (1–48): 300 VDC or 300 Vrms (425 V peak) for AC waveforms, 1 A switched, 60 W, 125 VA maximum.
-----------------------------	--

Contact Life (typ.)	>10 ⁵ operations at max. signal level. >10 ⁸ operations no load ¹ .
----------------------------	---

1. Minimum signal level 10 mV, 10 μA.

Contact Resistance	<1 Ω any path and additional 1 Ω at end of contact life.
---------------------------	--

Contact Potential	<3 μV per contact pair.
--------------------------	-------------------------

Offset Current	<100 pA.
-----------------------	----------

Connector Type	50-pin female D-shell for rows and columns. 25-pin female D-shell for "daisy-chain" rows. Supplied with male IDC ribbon cable connectors.
-----------------------	---

Isolation Between Any Two Terminals	>10 ⁹ Ω, <200 F.
--	-----------------------------

Isolation Between Any Terminal and Earth	>10 ⁹ Ω, <400 pF.
---	------------------------------

Cross Talk (1 MHz, 50 Ω Load)	<-35 dB.
--------------------------------------	----------

Insertion Loss (50 Ω Source, 50 Ω Load)	<0.35 dB below 1 MHz. <3 dB below 2 MHz.
--	--

Common Mode Voltage	300 VDC or 300 Vrms (425 V peak) for AC waveforms between any terminal and chassis.
----------------------------	---

General

Matrix Configuration	6 rows × 8 columns.
-----------------------------	---------------------

Contact Configuration	2 pole Form A.
------------------------------	----------------

Relay Type	Latching electromechanical.
-------------------	-----------------------------

Actuation Time	<3 ms.
-----------------------	--------

Environmental and Safety

Operating Environment:	Specified for 0° to 50°C. Specified to 80% R.H. at 35°C.
-------------------------------	---

Storage Environment:	-25° to 65°C.
-----------------------------	---------------

EMC:	Conforms to European Union EMC Directive.
-------------	---

Safety:	Conforms to European Union Low Voltage Directive
----------------	--

RoHS:	Conforms to European Union RoHS Directive
--------------	---

Weight	0.52 kg (1.16 lb).
---------------	--------------------

Supplied Accessories

7709-306A	50-pin D-Sub Male IDC Connector Kit
-----------	-------------------------------------

7709-307A	25-pin D-Sub Male IDC Connector Kit
-----------	-------------------------------------

Available Accessories

7789	50/25 Pin Male D-Shell Solder Cup Connectors
------	--

7790	50/50/25 Pin Female/Male D-Shell IDC Connectors
------	---

7705-MTC-2	50 Pin Male to Female D-sub Cable, 2m (6.6 ft).
------------	---

7707-MTC-2	25 Pin Male to Female D-sub Cable, 2m (6.6 ft).
------------	---

Available Services

7709-3Y-EW	1-year factory warranty extended to 3 years from date of shipment
------------	---

7710 20-channel Solid-state Differential Multiplexer with Automatic CJC

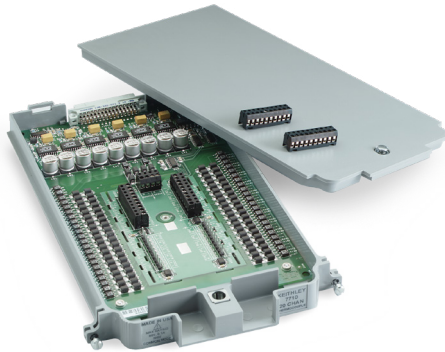

The 7710 plug-in module offers 20 channels of 2-pole or 10 channels of 4-pole relay input that can be configured as two independent banks of multiplexers. The relays are solid state, providing long life and low maintenance. Solid-state relays usually have 100 times longer life than mechanical relays. It is ideal for long-term data logging applications as well as for demanding high-speed applications.

Key Features

- 20 channels for general purpose measurements with scanning speeds up to 800 channels/s
- High speed production or ATE testing up to 500 channels/s
- Long lifetime solid state relays
- Removable screw terminals

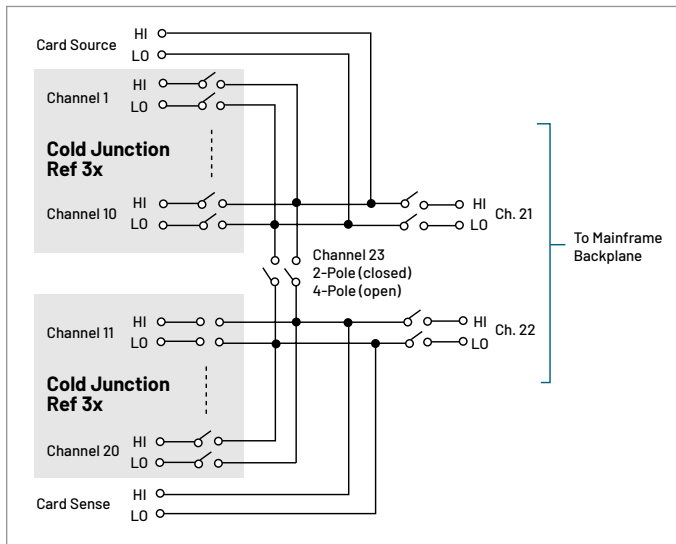

Specifications

Capabilities

Maximum Signal Level	Any channel to any channel (1-20) 60 VDC or 42 V rms, 100 mA switched, 6 W, 4.2 VA maximum.
Common Mode Voltage	300 VDC or 300 Vrms (425 V peak) maximum between any terminal and chassis.
Contact Life	>10 ¹⁰ operations at cold switching or max signal level (guaranteed by design).
Relay Drive Current	6 mA per channel continuous, 25 mA during initial pulse.
Contact Resistance	<10 Ω per channel or <5 Ω per conductor. Refer to the 7710 User's Guide for measurement considerations when used on the instrument 1 Ω or 10 Ω ranges.
Contact Potential	<3 μV per pair.
Offset Current	<3 nA @ 23°C (per channel); additional 0.13 nA/°C >23°C.
Connector Type	3.5 mm removable screw terminals, #20 AWG wire size.
Isolation Between Any Two Terminals:	>10 ¹⁰ Ω @ 23°C, > 8×10 ⁹ Ω @ 50°C, <100 pF.
Isolation Between Any Terminal and Earth:	>10 ¹⁰ Ω, <100 pF.
Crosstalk (CH-CH, 500 kHz, 50 Ω Load):	<-40 dB.
Insertion Loss (50 Ω Source, 50 Ω Load)	<1 dB below 500 kHz.
Scanning Speeds (see mainframe specifications for details)	
Multiple Channels, Into Memory	
	7710 Scanning DCV: >800.
	7710 Scanning DCV alternating 2WQ: >400.

General

Channels	20 channels of 2-pole relay input. All channels configurable to 4-pole.
Relay Type	Solid state opto-coupled FET.
Actuation Time	<0.5 ms (100 mA load).
Environmental and Safety	
	Operating Environment: Specified for 0° to 50°C. Specified to 80% R.H. at 35°C.
	Storage Environment: -25° to 65°C.
	EMC: Conforms to European Union EMC Directive.
	Safety: Conforms to European Union Low Voltage Directive
	RoHS: Conforms to European Union RoHS Directive
Weight	0.45 kg (1 lb).
Supplied Accessories	
CC-92-1	Set of 20 Cable Ties
TL-23	Screwdriver
Available Services	
7710-3Y-EW	1-year factory warranty extended to 3 years from date of shipment
Ordering Information	
7710	20-channel Solid-state Differential Multiplexer Module
Warranty	1 year

Contact Information:

Australia 1 800 709 465
Austria* 00800 2255 4835
Balkans, Israel, South Africa and other ISE Countries +41 52 675 3777
Belgium* 00800 2255 4835
Brazil +55 (11) 3530-8901
Canada 1 800 833 9200
Central East Europe / Baltics +41 52 675 3777
Central Europe / Greece +41 52 675 3777
Denmark +45 80 88 1401
Finland +41 52 675 3777
France* 00800 2255 4835
Germany* 00800 2255 4835
Hong Kong 400 820 5835
India 000 800 650 1835
Indonesia 007 803 601 5249
Italy 00800 2255 4835
Japan 81(3) 6714 3086
Luxembourg +41 52 675 3777
Malaysia 1 800 22 55835
Mexico, Central/South America and Caribbean 52(55) 88 69 35 25
Middle East, Asia, and North Africa +41 52 675 3777
The Netherlands* 00800 2255 4835
New Zealand 0800 800 238
Norway 800 16098
People's Republic of China 400 820 5835
Philippines 1 800 1601 0077
Poland +41 52 675 3777
Portugal 80 08 12370
Republic of Korea +82 2 565 1455
Russia / CIS +7(495) 6647564
Singapore 800 6011 473
South Africa +41 52 675 3777
Spain* 00800 2255 4835
Sweden* 00800 2255 4835
Switzerland* 00800 2255 4835
Taiwan 886 (2) 2656 6688
Thailand 1 800 011 931
United Kingdom / Ireland* 00800 2255 4835
USA 1 800 833 9200
Vietnam 12060128

* European toll-free number. If not accessible, call: +41 52 675 3777

Rev. 02.2022



Find more valuable resources at [TEK.COM](https://www.tek.com)

Copyright © Tektronix. All rights reserved. Tektronix products are covered by U.S. and foreign patents, issued and pending. Information in this publication supersedes that in all previously published material. Specification and price change privileges reserved. TEKTRONIX and TEK are registered trademarks of Tektronix, Inc. All other trade names referenced are the service marks, trademarks or registered trademarks of their respective companies.

121724 SBG 1KW-61317-2

